

340A/360A Series Single Stage End Suction Pumps

- Capacities to 4500 G.P.M. (850 M³/HR)
- Heads to 370 Feet (78 Meters)
- Temperatures to 300°F (149°C)



Model 362A



Model 344A



Model 341A

ap AURORA®

PENTAIR PUMP GROUP

Aurora 340A/360A Pumps

Setting New Standards of Efficiency

Liquid handling requirements are much more involved than they were five years ago. The variety of liquids being handled has increased along with temperatures and pressures. Today's installations demand quiet, smooth running pumps with long life. Aurora Pump's 80 years of experience with design, sales and manufacturing of centrifugal pumps has led to the 340A/360A Series. These modern pumps with a clean, straightforward design were developed with maximum interchangeability in mind. Aurora's highly reliable 340A/360A pumps offer an economical solution to your liquid handling problems.

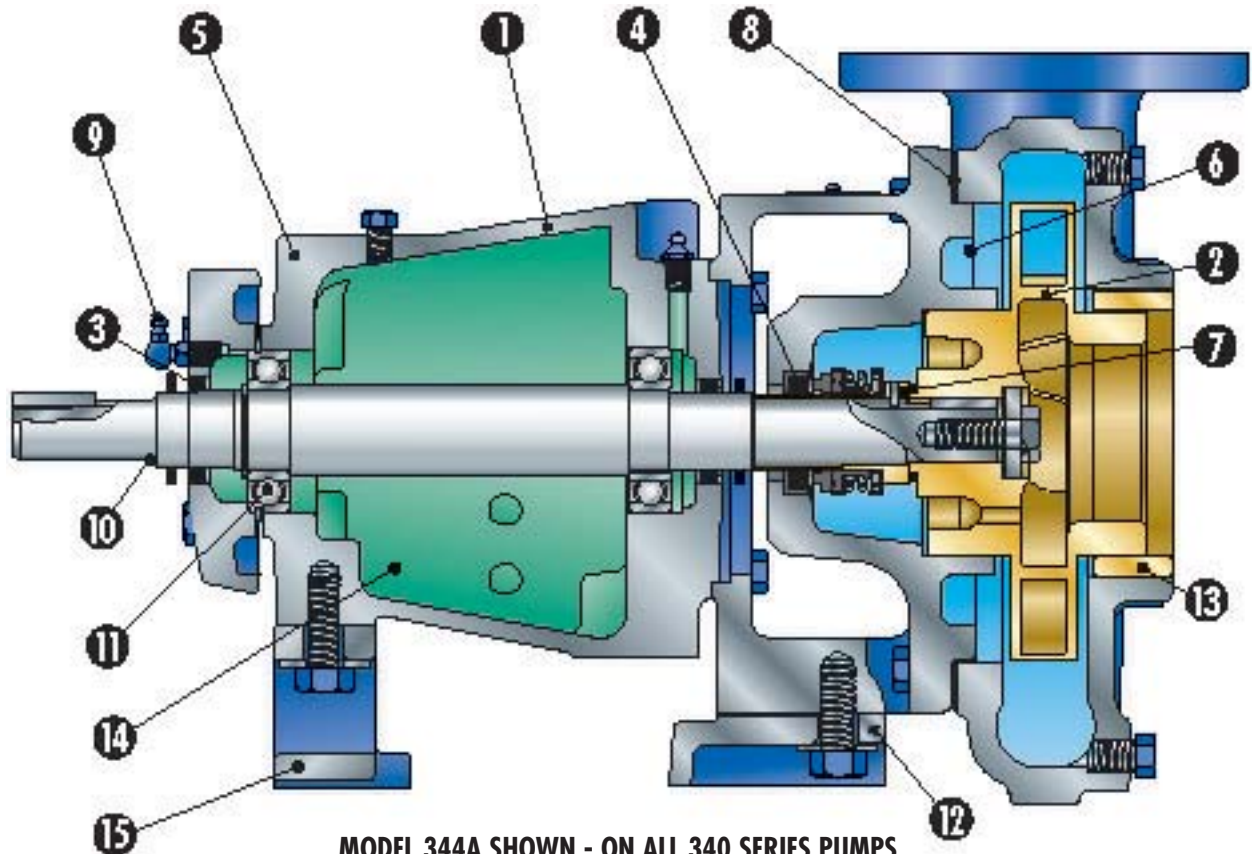

**MODEL 344A SHOWN - ON ALL 340 SERIES PUMPS
MECHANICAL SEALS ARE STANDARD**

Standard – 340A and 360A

- Discharge position No. 1
- Regreaseable bearings (Model 344A, 364A)
- Standard JM motor (Model 341A, 342A)
- Standard JP motor (Model 361A, 362A)
- Coupling guard (Model 344A, 364A)

Standard – 360A Only

- Interchangeable stuffing box
- Graphite impregnated acrylic packing

Optional – 340A and 360A

Standard 340A and 360A series pumps are designed to meet the requirements of most applications. However, to meet special services, a number of optional features have been made available. For services not handled by the features listed, refer to the factory.

- All iron construction
- 316 stainless steel sleeve
- Stainless steel shaft
- Impeller wearing rings
- Oil lubricated ball bearings (Model 344A, 364A)
- Sealed permanently lubricated ball bearings (power frames No. 1, 2 and 3)

Alternate discharge positions No. 2, 3 and 4 (see pages 12 and 13)

- Fabricated stainless steel drip-rim bases (Model 344A, 364A)
- Formed steel bases (Model 344A, 364A)
- High temperature mechanical seal
- Variety of alternative constructions

Optional – 360A Only

- All bronze construction
- Hardened shaft sleeve (for packing)
- Various mechanical seal types
- Water jacketed stuffing box
- Semi-open impellers (Model 364A)
- Double row thrust bearings (Model 364A)
- Packing with lantern ring

Features

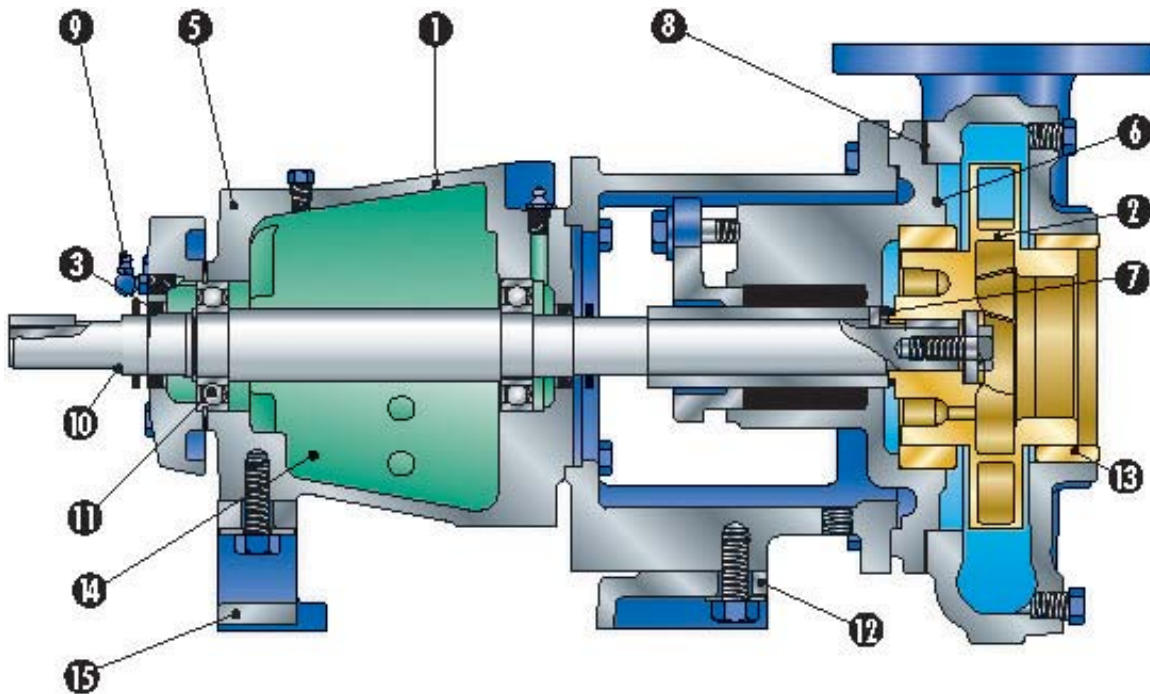

MODEL 364A SHOWN - ON ALL 360 SERIES PUMPS PACKING IS STANDARD, MECHANICAL SEALS ARE OPTIONAL

- 1 COMPUTER MACHINED major components with 360A degree registered fits to assure concentricity of all pump parts.
- 2 PRECISION CAST, DYNAMICALLY BALANCED, ENCLOSED IMPELLER is keyed to the shaft extension and secured by a capscrew and washer. Gaskets are used to prevent leakage to shaft end.
- 3 OIL SEALS and non-sparking Neoprene rotating slingers protect both bearings during pump operation and pump washdown.
- 4 MECHANICAL SEAL has hot water carbon against Ni-Resist face for optimum hot water performance. Long life is also assured with 303 stainless steel metal parts and "Buna-N" elastomer.
- 5 POWER FRAME provides heavy duty maximum interchangeability for flexible coupled applications.
- 6 HYDROSTATIC TEST of pumps at factory guarantees casting and seal integrity.
- 7 BRONZE SHAFT SLEEVE prevents shaft wear, is slip fit over the shaft, keylocked and extends the full length of seal box to eliminate corrosion of the shaft by the pumped liquid. This cancels the requirement for high cost, special stainless steel or alloy shafts.
- 8 BACK PULL-OUT design simplifies disassembly. The suction and discharge piping is not disturbed at disassembly.
- 9 LUBRICATION FITTINGS are conveniently located for quick accessibility and provides positive bearing lubrication. Oil lubrication optionally available.
- 10 CARBON STEEL SHAFT designed for minimum deflection, not to exceed .002" at the sealing faces at maximum load.
- 11 BEARINGS selected for 3 year minimum life at maximum load. Average bearing life 5 x minimum. Grease lube standard.
- 12 CLOSE COUPLED MOTORS in smaller frame sizes are supported off of the motor bracket for maximum rigidity.
- 13 CASE WEARING RING prevents wear on casing and is easily and inexpensively replaced. Impeller rings are available. Front case wearing rings are standard on all models and size pumps. Rear case wearing rings are standard only on 2" discharge and larger model 360A series pumps. Front impeller wearing rings are optional on all models and size pumps. Rear impeller wearing rings are optional only on 2" discharge and larger model 340A and 360A series pumps.
- 14 LARGE CAPACITY OIL RESERVOIR is provided on power frame Model 344A and 364A pumps for optional oil lube.
- 15 REAR SUPPORT FOOT provides support and simplifies coupling alignment. All supports are slotted to simplify back pull-out of power frame.

Material of Construction and Design Details

Material of Construction

Pump Part	Standard Fitted	Bronze Fitted	All-Iron	*All-Bronze
Casing	Cast Iron ASTM A48	Cast Iron ASTM A48	Cast Iron ASTM A48	Bronze ASTM B62
Case Wearing Ring	Bronze ASTM B62	Bronze ASTM B62	Cast Iron ASTM A48	Bronze ASTM B62
Impeller	Cast Iron ASTM A48	Bronze ASTM B584	Cast Iron ASTM A48	Bronze ASTM B584
Motor Bracket	Cast Iron ASTM A48	Cast Iron ASTM A48	Cast Iron ASTM A48	Cast Iron ASTM A48
Shaft	Steel AISI C1045	Steel AISI C1045	Steel AISI C1045	Steel AISI C1045
Sleeve	Bronze ASTM B62	Bronze ASTM B62	Stainless Steel AISI 316	Bronze ASTM B62
Power Frame (344A & 364A)	Cast Iron ASTM A48	Cast Iron ASTM A48	Cast Iron ASTM A48	Cast Iron ASTM A48
Mechanical Seal 340A Series	303 stainless steel metal parts, "Buna-N" elastomer parts, Ni-Resist seat and carbon washer			303 stainless steel metal parts, viton elastomer, ceramic seat, and carbon washer
360A Series (Optional)				
Stuffing Box	Cast Iron ASTM A48	Cast Iron ASTM A48	Cast Iron ASTM A48	Bronze ASTM B62
Packing (Standard) 360A Series Only	Interwoven, graphited fiber diagonally cut			

* All Bronze optionally available in 361A and 364A pumps only.

Design Details

Area	Description	Power Frame			
		1	2	3	21
Pump Shaft	Rotation—from driver end	CW	CW	CW	CW
	Diameter at impeller	7/8	1-1/4	1-1/4	1-5/8-12
	Diameter at shaft sleeve	1	1-3/8	1-3/8	2-1/4
	Diameter between bearings	1-3/8	1-15/16	2-3/8	3-1/4
	Diameter at coupling end	7/8	1-1/8	1-1/8	2-3/8
	Coupling key—square	3/16	1/4	1/4	5/8
	Max. deflection at seal face	.002	.002	.002	.002
Ball Bearings	Bearing (inboard radial)	206K	308K	310K	313
	Bearing (outboard thrust)	206KG	308KG	310KG	5313
	Bearing centers	5-11/16	7-11/16	7-11/16	9-5/8
	Bearing type	Ball	Ball	Ball	Ball
	Min B ₁₀ bearing life under maximum load	3 years	3 years	3 years	3 years
Sleeve	Packing size 360A series	3/8	3/8	3/8	7/16
	Outside diameter of sleeve 360A series	1-1/2	1-7/8	1-7/8	2-1/2
	Outside diameter of sleeve 340A series	1-1/8	1-1/2	1-1/2	N/A

Design Details

340A Series

Sealing Method	Temperature °F	
	Close Coupled	Frame Mounted
Standard Mechanical Seal	225	225

360A Series

Sealing Method	Temperature °F	
	Close Coupled	Frame Mounted
Standard Mechanical Seal	225	225
W/J Mechanical Seal*	300	300
Standard Packing	225	225
W/J Packing*	275	275
Packing . . . Suction lift requires lantern ring. * 7, 9 and 12 bore pumps only		
340A & 360A Series Case Working Pressure (all or any part can be suction pressure) 175 P.S.I.		
Hydrostatic Test Pressure (Maximum) 265 P.S.I		

Limitations 340A & 360A Series - H.P.

Speed-RPM		3500	1750	1150
Close Coupled	O.D.P.	60	50	30
	T.E. & EX. PR.	50	50	30
Power Frame	1	40	20	15
	2 & 3	125	75	40
	21	N/A	250	150

End suction products such as the flexible coupled horizontal pump seen below are used in offices and high rise buildings for internal environment control. End suction pumps for HVAC installation come in a variety of configurations including close coupled, flexible coupled, horizontal or vertical mounted units.



340 Range Charts

3500 RPM

INDIVIDUAL PERFORMANCE CURVES SHOULD BE CHECKED FOR FINAL SELECTION. FOR SELECTIONS NOT SHOWN ON THIS CHART PLEASE REFER TO THE FACTORY.

- POWER FRAME NO. 1
- POWER FRAME NO. 2
- POWER FRAME NO. 3

MAXIMUM HORSEPOWER	CLOSE	OPEN DRIP PROOF	60
	COUPLED	TE & EX PR	50
	FRAME MOUNTED		100

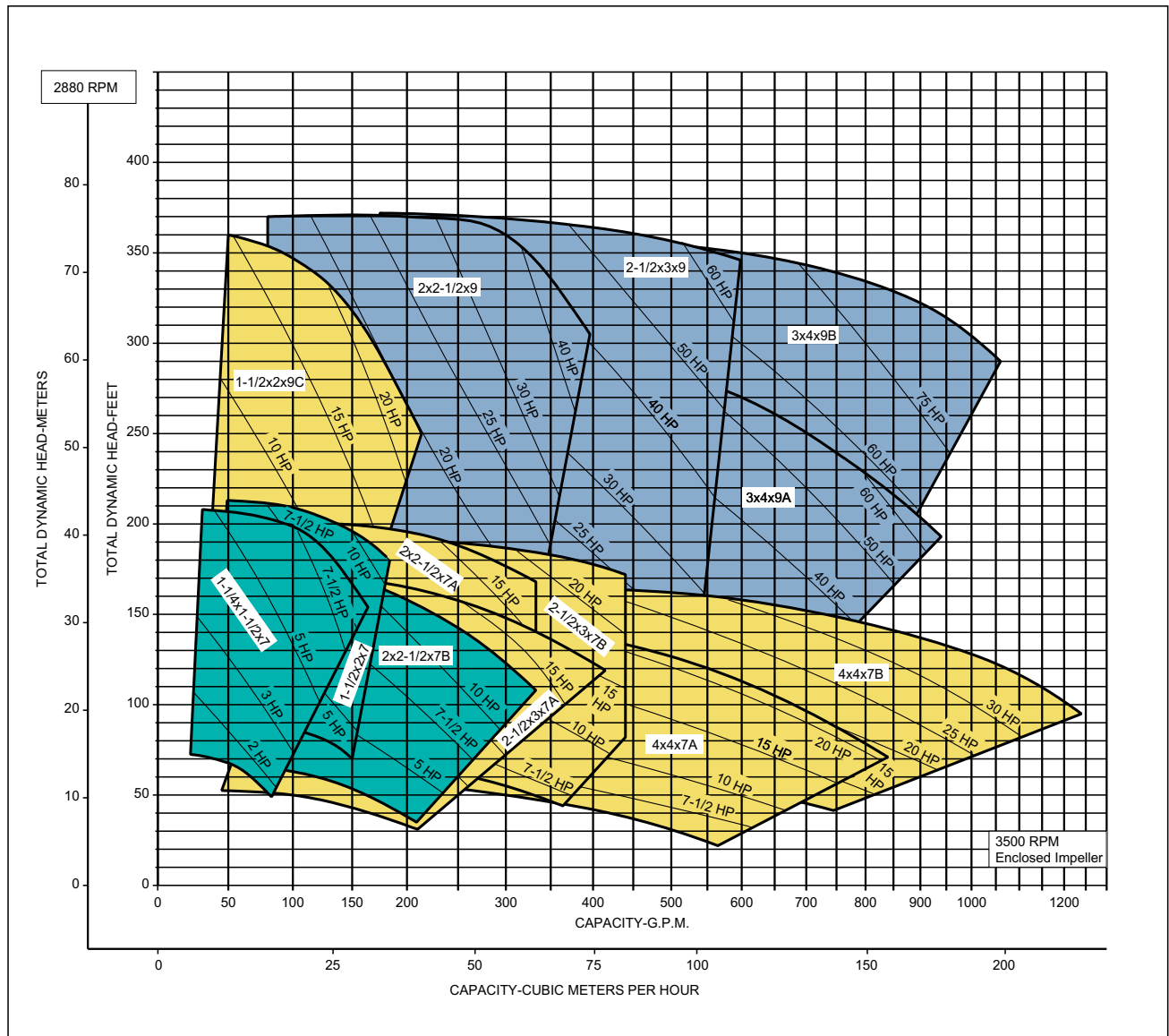

340 Range Charts

1750 RPM

INDIVIDUAL PERFORMANCE CURVES SHOULD BE CHECKED FOR FINAL SELECTION. FOR SELECTIONS NOT SHOWN ON THIS CHART PLEASE REFER TO THE FACTORY.

- POWER FRAME NO. 1
- POWER FRAME NO. 2
- POWER FRAME NO. 3

MAXIMUM HORSEPOWER	CLOSE COUPLED	OPEN DRIP PROOF TE & EX PR	50
	FRAME MOUNTED		100

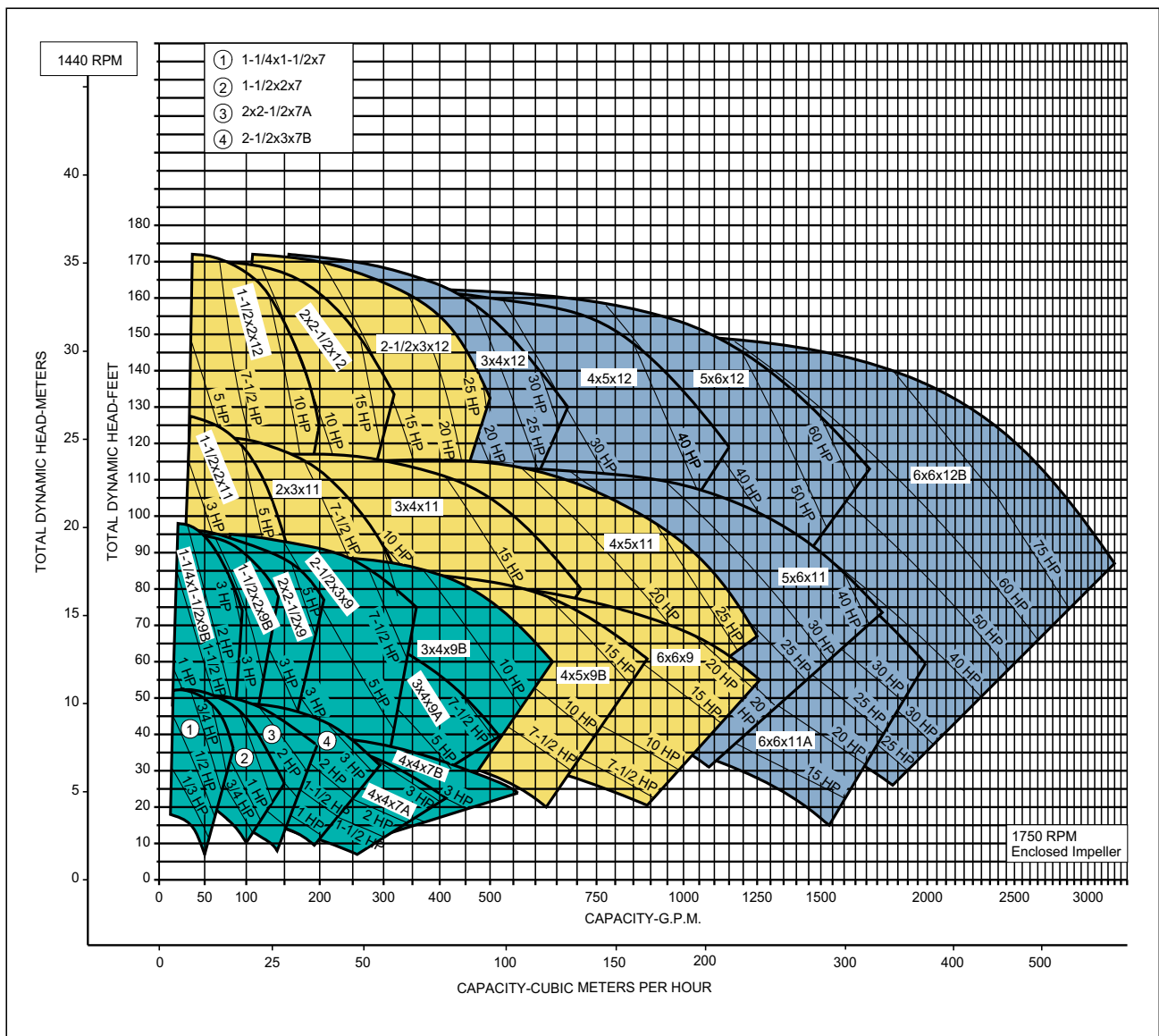

360 Range Charts

3500 RPM

INDIVIDUAL PERFORMANCE CURVES SHOULD BE CHECKED FOR FINAL SELECTION. FOR SELECTIONS NOT SHOWN ON THIS CHART PLEASE REFER TO THE FACTORY.

POWER FRAME NO. 1
 POWER FRAME NO. 2
 POWER FRAME NO. 3

MAXIMUM HORSEPOWER	CLOSE COUPLED	OPEN DRIP PROOF TE & EX PR	60
	FRAME MOUNTED		50
			100

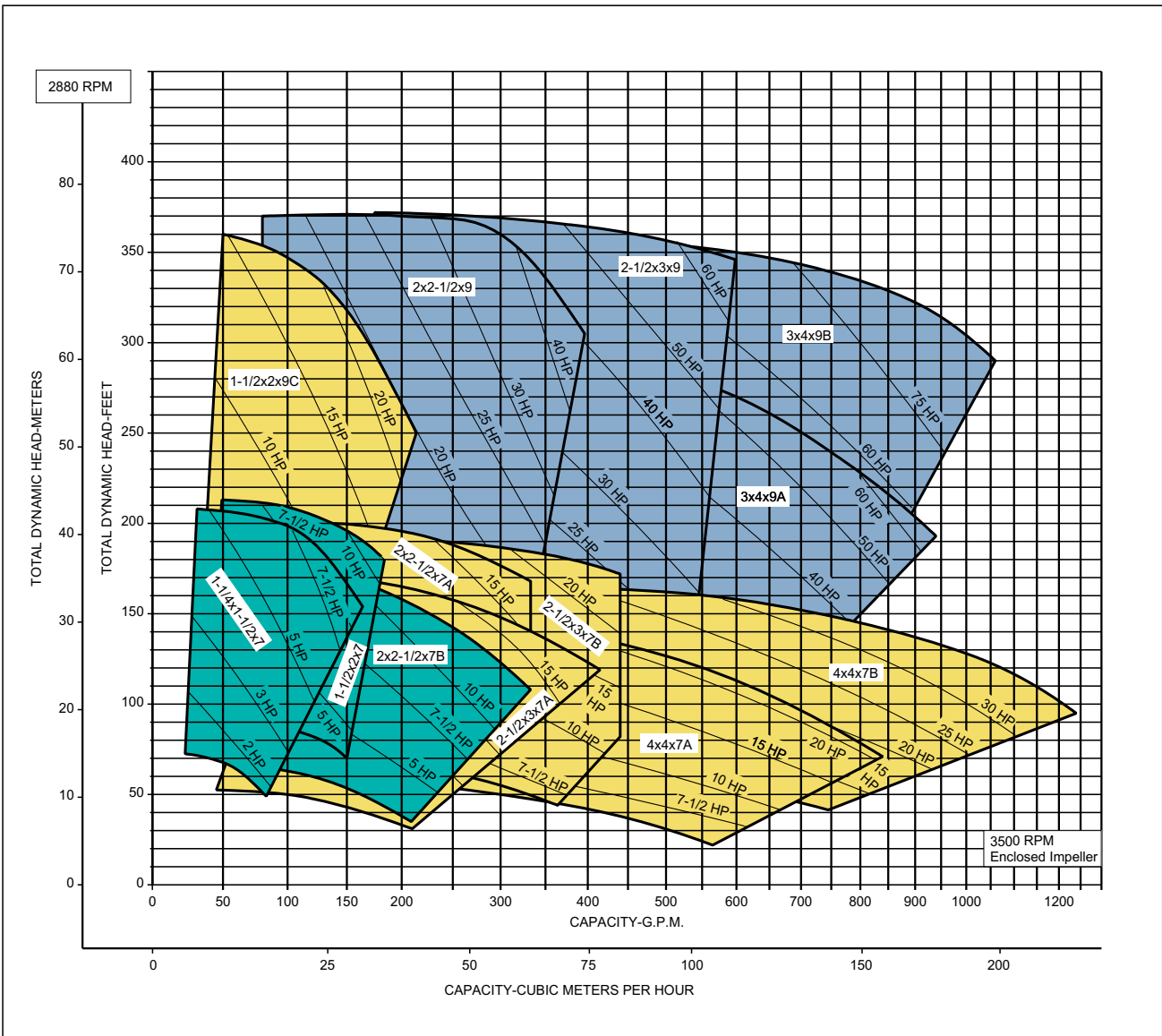

360 Range Charts

1750 RPM

INDIVIDUAL PERFORMANCE CURVES SHOULD BE CHECKED FOR FINAL SELECTION. FOR SELECTIONS NOT SHOWN ON THIS CHART PLEASE REFER TO THE FACTORY.

- POWER FRAME NO. 1
- POWER FRAME NO. 2
- POWER FRAME NO. 3
- POWER FRAME NO. 21

MAXIMUM HORSEPOWER	CLOSE COUPLED	OPEN DRIP PROOF	50
	FRAME MOUNTED	TE & EX PR	50
			250

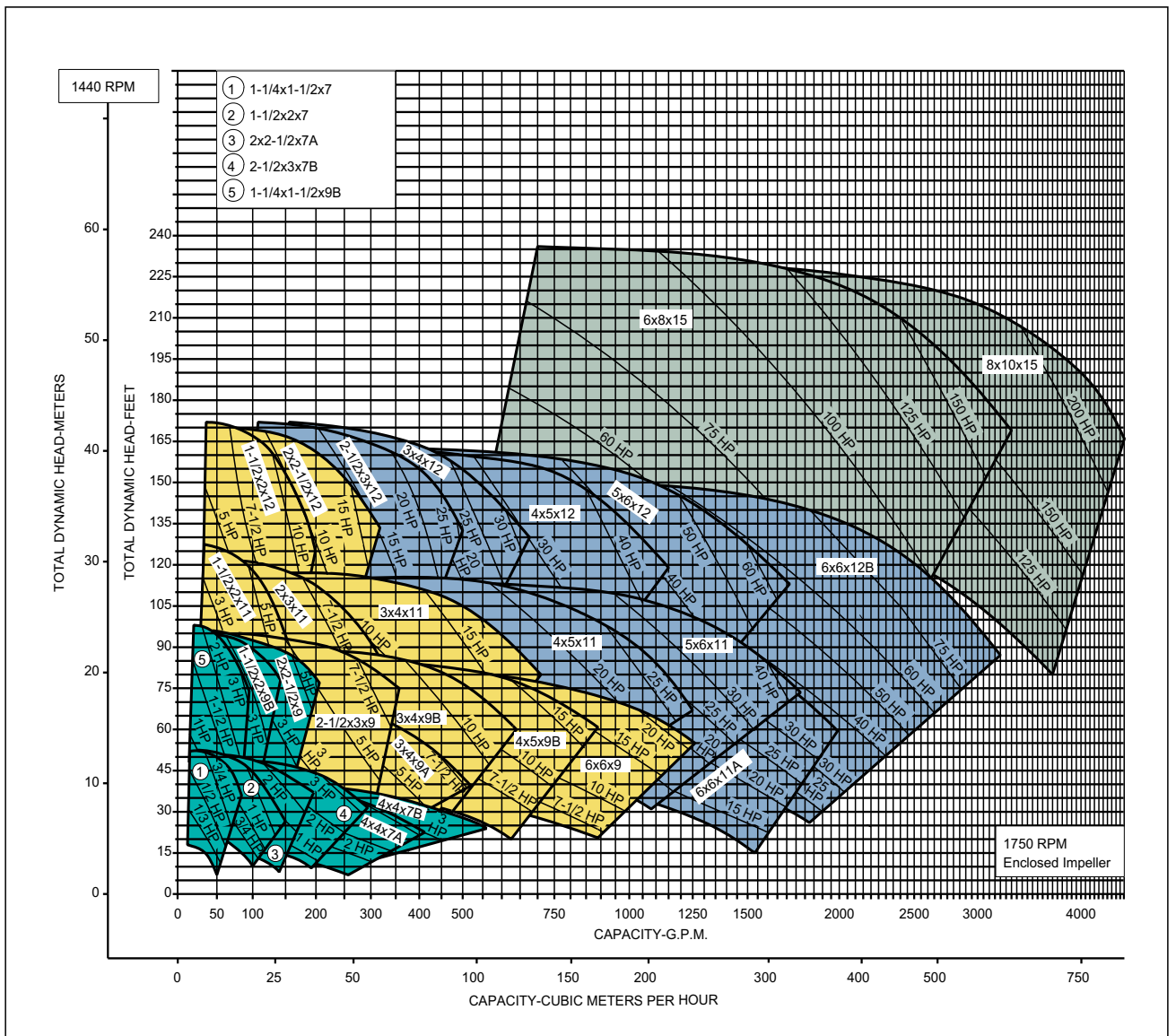

Engineering Details

Power Frame

Pump Size	Model 344A			Model 364A				
	3500	1750	1150	3500	1750		1150	
	R.P.M.	R.P.M.	R.P.M.	R.P.M.	R.P.M.		R.P.M.	
				ENC.	ENC.	SEMI.	ENC.	SEMI.
1-1/4 x 1-1/2 x 7	1	1	*	1	1	1	*	*
1-1/4 x 1-1/2 x 9B	*	1	*	*	1	*	*	*
1-1/2 x 2 x 7	1	1	*	1	1	1	*	*
1-1/2 x 2 x 9A	*	1	*	*	1	2	*	1
1-1/2 x 2 x 9B	*	1	*	*	1	*	*	*
1-1/2 x 2 x 9C	2	1	*	2	1	*	*	*
1-1/2 x 2 x 11	3	2	2	*	2	*	2	*
1-1/2 x 2 x 12	*	2	2	*	2	3	2	2
2 x 2-1/2 x 7A	2	1	*	2	1	1	*	*
2 x 2-1/2 x 7B	1	1	*	1	1	*	*	*
2 x 2-1/2 x 9	3	1	*	3	1	*	*	*
2 x 2-1/2 x 12	*	2	2	*	2	*	2	*
2 x 3 x 11	*	2	2	*	2	*	2	*
2-1/2 x 3 x 7A	1	1	*	2	1	1	*	*
2-1/2 x 3 x 7B	2	1	*	2	1	*	*	*
2-1/2 x 3 x 9	3	1	*	3	2	2	*	2
2-1/2 x 3 x 12	*	2	2	*	3	3	2	2
3 x 4 x 9A	3	1	*	3	2	*	*	*
3 x 4 x 9B	3	1	*	3	2	*	*	*
3 x 4 x 11	*	2	2	*	2	*	2	*
3 x 4 x 12	*	3	2	*	3	3	2	2
4 x 4 x 7A	2	1	*	2	1	*	*	*
4 x 4 x 7B	2	1	*	2	1	1	*	*
4 x 5 x 9A	3	2	*	3	2	*	*	*
4 x 5 x 9B	*	2	*	*	2	2	*	2
4 x 5 x 11	*	2	2	*	3	*	2	*
4 x 5 x 12	*	3	2	*	3	3	2	2
5 x 6 x 11	*	3	2	*	3	*	2	*
5 x 6 x 12	*	3	2	*	3	3	3	2
6 x 6 x 9	*	2	2	*	2	2	2	2
6 x 6 x 11	*	3	2	*	3	*	2	*
6 x 6 x 11A	*	3	2	*	3	*	2	*
6 x 6 x 12B	*	3	3	*	3	*	3	*
6 x 6 x 12B	*	3	*	*	3	*	*	*
6 x 8 x 15	*	*	*	*	21	*	21	*
8 x 10 x 15	*	*	*	*	21	*	21	*

* = Not Available

ENC.=Enclosed Impeller

SEMI.=Semi Open Impeller (Optional)

Engineering and Dimension Details

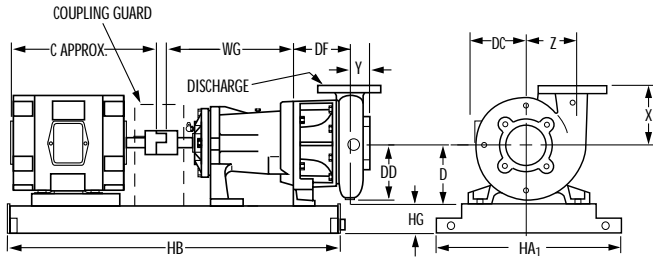

340A Series

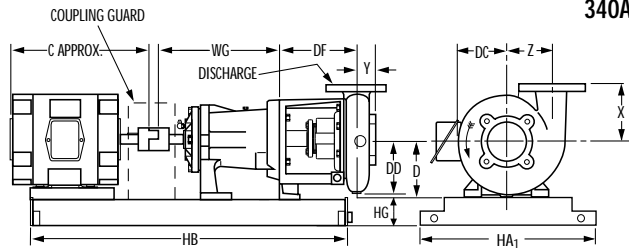

360A Series

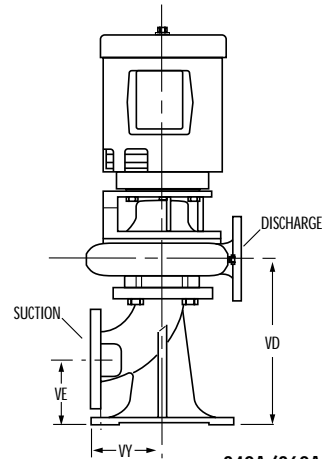

342A/362A Series

Pumps with Threaded Connections								340A Series			360A Series		342A/362A		
Pump Size			X	Y	Z	DC	DD	DF			DF		Vertical Pumps		
Discharge	Suction	Case Bore						Frame 1 143JM- 215JM	Frame 2 or 3 254JM- 256JM	Frame 2 or 3 284JM- 326JM	Frame 1 143JP- 184JP	Frame 2, 3 or 21 213JP- 325JP	VD	VE	VY
1-1/4	1-1/2	7	5-1/4	2-7/16	4-3/16	4-15/16	5-3/16	4-3/4	N/A	N/A	7-13/16	N/A	9-3/8	3-3/4	4
1-1/4	1-1/2	9B	6-3/8	2-9/16	5-3/8	6-3/16	6-3/8	4-11/16	N/A	N/A	7-3/4	N/A	9-3/8	3-3/4	4
1-1/2	2	7	5-3/8	2-1/2	4-5/16	5-1/8	5-3/8	4-13/16	N/A	N/A	7-7/8	N/A	10-5/16	4-1/8	4-1/2
1-1/2	2	9	6-3/4	2-5/8	5-1/2	6-5/16	6-9/16	4-3/4	5-3/4	5-3/4	7-13/16	8-5/8	10-5/16	4-1/8	4-1/2
1-1/2	2	11	9	2-13/16	6-1/8	7-1/16	7-1/4	N/A	5-3/4	5-3/4	N/A	8-5/8	10-1/2	4-1/8	4-1/2
1-1/2	2	12	7-3/4	2-3/4	7-1/16	8	8-1/4	N/A	5-7/8	N/A	N/A	8-3/4	10-7/16	4-1/8	4-1/2
Pumps with Ansi Standard 125 Lb. Flanged Connections															
2	2-1/2	7	5-5/8	1-7/8	4-9/16	5-3/8	5-13/16	4-15/16	5-15/16	N/A	8	8-13/16	11-7/16	4-1/2	5
2	2-1/2	9	7	1-7/8	5-11/16	6-1/2	6-7/8	4-7/8	5-7/8	5-7/8	7-15/16	8-3/4	11-7/16	4-1/2	5
2	2-1/2	12	8	1-7/8	7-3/16	8-3/16	8-1/2	5	6	N/A	N/A	8-7/8	11-7/16	4-1/2	5
2	3	11	8	2-3/8	6-1/2	7	7-3/8	5-1/8	6-1/8	N/A	N/A	8-5/8	12-7/8	5	5-1/2
2-1/2	3	7	5-7/8	2	4-13/16	5-13/16	6-1/4	5-1/16	6-1/16	N/A	8-1/8	8-15/16	12-9/16	5	5-1/2
2-1/2	3	9	7-1/4	2	5-15/16	6-3/4	7-1/4	5	6	6	8-1/16	8-7/8	12-9/16	5	5-1/2
2-1/2	3	12	8-1/4	2	7-3/8	8-3/8	8-3/4	5-1/8	6-1/8	N/A	N/A	9	12-9/16	5	5-1/2
3	4	9	7-1/2	2-1/8	6-1/8	6-7/8	7-7/16	5-1/8	6-1/8	6-1/8	8-3/16	9	14-11/16	6	6-1/2
3	4	11	9	2-3/4	7	7-9/16	8-3/16	5-7/16	6-7/16	N/A	N/A	9-1/8	15-1/4	6	6-1/2
3	4	12	8-1/2	2-1/8	7-9/16	8-7/16	8-15/16	5-1/2	6-1/2	6-1/2	N/A	9-1/8	14-11/16	6	6-1/2
4	4	7	6-1/2	2-1/2	5-1/2	6-7/16	7-5/16	5-7/16	6-7/16	6-7/16	8-1/2	9-5/16	14-15/16	6	6-1/2
4	5	9A	7-1/4	3-1/8	5-3/4	6-11/16	7-3/8	5-1/4	6-1/4	6-1/4	N/A	9-1/8	17-3/16	6-1/2	7-1/2
4	5	9B	7-3/4	2-5/8	6-5/8	8-1/16	8-11/16	5-3/8	6-3/8	N/A	N/A	9-1/4	16-11/16	6-1/2	7-1/2
4	5	11	9	3	7-1/4	7-15/16	8-11/16	5-5/8	6-5/8	6-5/8	N/A	9-1/4	17	6-1/2	7-1/2
4	5	12	8-3/4	2-5/8	7-15/16	8-7/8	9-9/16	N/A	6-3/4	6-3/4	N/A	9-3/8	16-11/16	6-1/2	7-1/2
5	6	11	9	3-1/8	8-1/16	8-11/16	10-1/8	6	7	7	N/A	9-5/8	18-1/8	7	8
5	6	12	9	2-7/8	8-5/16	9-1/4	10-1/8	N/A	7	7	N/A	9-5/8	17-7/8	7	8
6	6	9	8-1/4	2-3/4	7	8	9	5-1/2	6-1/2	6-1/2	N/A	9-3/8	17-13/16	7	8
6	6	11	9-1/4	3-1/8	8-11/16	9-11/16	10-13/16	N/A	7-1/4	7-1/4	N/A	9-7/8	18-1/4	7	8
6	6	11A	9-1/4	3-1/8	8-11/16	9-11/16	10-13/16	N/A	7-1/4	7-1/4	N/A	9-7/8	18-1/4	7	8
6	6	12B	9-1/4	3-1/8	8-11/16	9-11/16	10-13/16	N/A	7-1/4	7-1/4	N/A	9-7/8	18-1/4	7	8
6	8	15	18	6	—	10-7/16	14-1/2	N/A	N/A	N/A	N/A	10-3/16*	N/A	N/A	N/A
8	10	15	19	6	—	11	14-1/2	N/A	N/A	N/A	N/A	10-5/16*	N/A	N/A	N/A

* Power Frame 21 Only

340A Series Engineering and Dimension Details

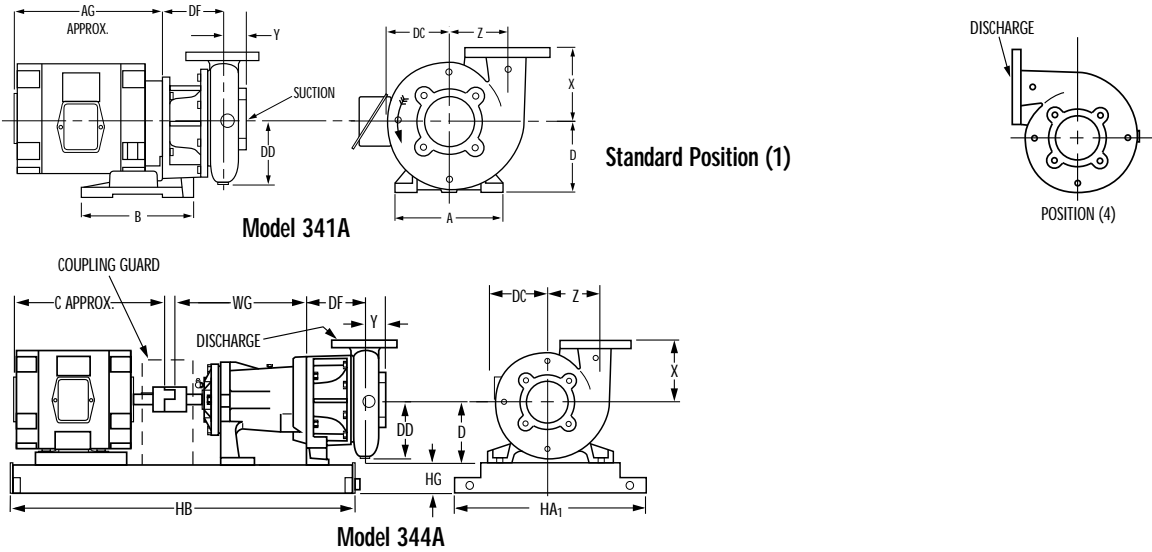

Pump Model	Base Number	Weight Lbs.	HA ₁	HB	HG	Power Frame					
						Weight in Pounds	1	2	3		
344A	4	49	17-1/4	30-1/2	3	D	Case Bore	7	5-1/4	6-1/4	—
	5	59	17-1/4	36-1/2	3			9	6-1/4	7	7
	7	82	20-1/2	36-1/2	3			11	—	7	7
	8	96	20-1/2	42-1/2	3			12	—	7	7
	11	164	26-3/4	46-1/2	4			WG	10-5/16	13-13/16	13-13/16
15	291	30-3/4	54-1/2	4-1/2							

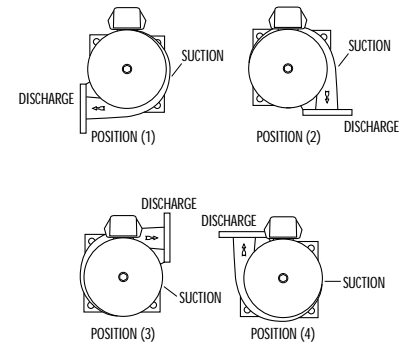

Pump Model	Motor Frame	Horsepower			Mtr. Wgt. Lbs.	D	Pump Model 341A				Base Number		
		3500 RPM	1750 RPM	1150 RPM			A	B	AG	C			
344A	56	—	1/2-3/4	—	50	5-1/4	—	—	—	12	4	N/A	N/A
341A 342A & 344A	143T	1-1/2	1	3/4	30	5-1/4	9-3/4	8-5/8	10	12	4	N/A	N/A
	145T	2-3	1-1/2-2	1	35	5-1/4	9-3/4	8-5/8	11	13	4	7	N/A
	182T	5	3	1-1/2	45	5-1/4	9-3/4	8-5/8	11	13	4	7	N/A
	184T	7-1/2	5	2	50	5-1/4	9-3/4	8-5/8	12	14	4	7	N/A
	213T	10	7-1/2	3	120	5-1/4	10-1/2	7-1/2	14	16	4	7	N/A
	215T	15	10	5	144	5-1/4	10-1/2	9	15	18	5	7	N/A
	254T	20	15	7-1/2	217	6-1/4	12-1/2	10-3/4	17	21	7	8	8
	256T	25	20	10	246	6-1/4	12-1/2	12-1/2	19	23	N/A	8	8
	284T	—	25	15	320	7	13-3/4	11-1/2	19	24	N/A	8	8
	284TS	30	—	—	320	7	13-3/4	11-1/2	19	22	N/A	8	8
	286T	—	30	20	351	7	13-3/4	13	21	25	N/A	8	8
	286TS	40	—	—	351	7	13-3/4	13	21	24	N/A	8	8
	324T	—	40	25	442	8	16	14	22	26	N/A	11	11
324TS	50	—	—	442	8	16	14	22	25	N/A	11	11	
326T	—	50	30	485	8	16	15-1/2	23	28	N/A	11	11	
326TS	60	—	—	485	8	16	15-1/2	23	26	N/A	11	11	
344A	364T	—	—	40	540	9	18	15-1/2	23	29	N/A	11	11
	364TS	75	60	—	540	9	18	15-1/2	23	27	N/A	11	11
	365TS	100	75	—	590	9	18	15-1/2	24	28	N/A	11	11
	404TS	125	100	—	690	10	20	16-1/4	26	30	N/A	15	15

Notes:

- Dimensions and weights are approximate.
- All dimensions are in inches and may vary ±1/4" (6).
- Frame sizes, "C" and "AG", dimension and motor weight are for open drip-proof motors only.
- Conduit box is shown in approximate position. Dimensions are not specified as they vary with each motor manufacturer.
- Not for construction purposes unless certified.
- Discharge positions No. 2 and 3 are not available on Models 341A, 361A, 344A and 364A. Position No. 1 is furnished as standard unless otherwise specified.
- When two "D" dimensions are indicated, always use the larger figure.
- Power frame selection for 344A pumps can be made from the range charts.
- Model 341A and 342A have "JM" motor frames. Model 344A has "T" frame motor.

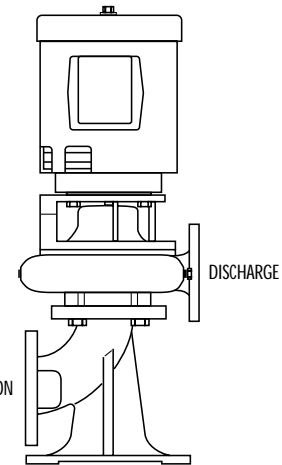

Model 342A

360A Series Engineering and Dimension Details

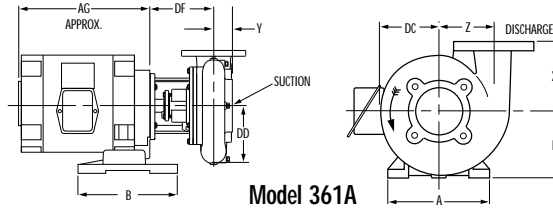
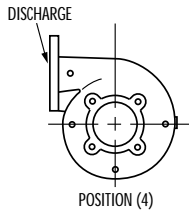

Standard Position (1)

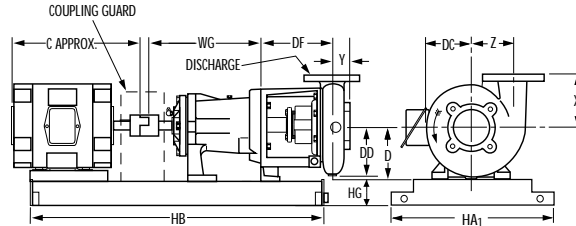

Model 364A

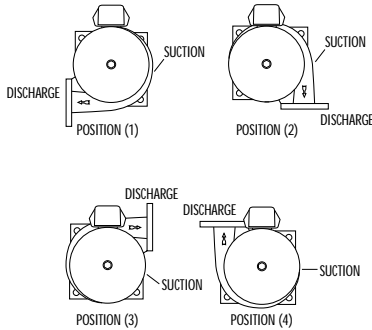

Pump Model	Base Number	Weight Lbs.	HA ₁	HB	HG	Power Frame Weight in Pounds	1	2	3	21	
364A	4	49	17-1/4	30-1/2	3	D Case Bore	7	5-1/4	6-1/4	—	—
	5	59	17-1/4	36-1/2	3		9	6-1/4	7	7	—
	7	82	20-1/2	36-1/2	3		11	—	7	7	—
	8	96	20-1/2	42-1/2	3		12	—	7	7	—
	9	109	20-1/2	48-1/2	3		15	—	—	—	14-1/2
	WG	11	164	26-3/4	46-1/2	4	10-5/16	13-13/16	13-13/16	—	—
		12	221	26-3/4	54-1/2	4	—	—	—	—	—
		15	291	30-3/4	54-1/2	4-1/2	—	—	—	—	—
		16	345	30-3/4	64-1/2	4-1/2	—	—	—	—	—
		17	399	30-3/4	74-1/2	4-1/2	—	—	—	—	—

Pump Model	Motor Frame	Horsepower			Mtr. Wgt. Lbs.	D	Pump Model 361A			C	Base Number			
		3500 RPM	1750 RPM	1150 RPM			A	B	AG		1	2	3	21
364A	56	—	1/2-3/4	—	50	5-1/4	—	—	—	12	4	N/A	N/A	N/A
361A 362A & 364A	143T	1-1/2	1	3/4	30	5-1/4	9-3/4	8-5/8	10	12	4	N/A	N/A	N/A
	145T	2-3	1-1/2-2	1	35	5-1/4	9-3/4	8-5/8	11	13	4	7	N/A	N/A
	182T	5	3	1-1/2	45	5-1/4	9-3/4	8-5/8	11	13	4	7	N/A	N/A
	184T	7-1/2	5	2	50	5-1/4	9-3/4	8-5/8	12	14	4	7	N/A	N/A
	213T	10	7-1/2	3	120	5-1/4	10-1/2	7-1/2	14	16	4	7	7	N/A
	215T	15	10	5	144	5-1/4	10-1/2	9	15	18	5	7	7	N/A
	254T	20	15	7-1/2	217	6-1/4	12-1/2	10-3/4	17	21	N/A	8	8	N/A
	256T	25	20	10	246	6-1/4	12-1/2	12-1/2	19	23	N/A	8	8	N/A
	284T	—	25	15	320	7	13-3/4	11-1/2	19	24	N/A	8	8	N/A
	284TS	30	—	—	320	7	13-3/4	11-1/2	19	22	N/A	8	8	N/A
	286T	—	30	20	351	7	13-3/4	13	21	25	N/A	9	9	16
	286TS	40	—	—	351	7	13-3/4	13	21	24	N/A	8	8	N/A
	324T	—	40	25	442	8	16	14	22	26	N/A	11	11	16
	324TS	50	—	—	442	8	16	14	22	25	N/A	11	11	N/A
	326T	—	50	30	485	8	16	15-1/2	23	28	N/A	11	11	16
	326TS	60	—	—	485	8	16	15-1/2	23	26	N/A	11	11	N/A
	364A	364T	—	—	40	540	9	18	15-1/2	23	29	N/A	12	12
364TS		75	60	—	540	9	18	15-1/2	23	27	N/A	11	11	16
365T		—	—	50	590	9	18	15-1/2	24	28	N/A	N/A	N/A	16
365TS		100	75	—	590	9	18	15-1/2	24	28	N/A	11	11	16
404T		—	100	60	690	10	20	16-1/4	26	33	N/A	N/A	N/A	17
404TS		125	100	—	690	10	20	16-1/4	26	30	N/A	15	15	17
405T		—	—	75	780	10	20	17-3/4	27	34	N/A	N/A	N/A	17
405TS		—	125	—	780	10	20	17-3/4	27	31	N/A	N/A	N/A	17
444TS		—	150	—	950	11	22	18-1/2	30	34	N/A	N/A	N/A	17
445TS		—	200	—	1000	11	22	20-1/2	32	36	N/A	N/A	N/A	17

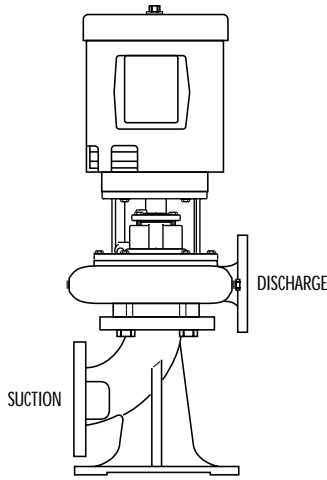

Notes:

- Dimensions and weights are approximate.
- All dimensions are in inches and may vary $\pm 1/4"$ (6).
- Frame sizes, "C" and "AG", dimension and motor weight are for open drip-proof motors only.
- Conduit box is shown in approximate position. Dimensions are not specified as they vary with each motor manufacturer.
- Not for construction purposes unless certified.
- Discharge positions No. 2 and 3 are not available on Models 341A, 361A, 344A and 364A. Position No. 1 is furnished as standard unless otherwise specified.
- When two "D" dimensions are indicated, always use the larger figure.
- Power frame selection for 364A pumps can be made from the range charts.
- Model 361A and 362A have "JP" motor frames. Model 364A has "T" frame motor.

Engineering Specifications

Flexible-Close Coupled Pumps

The contractor shall furnish (and install as shown on the plans) Aurora Model (341A horizontal close coupled) (342A vertical close coupled) (344A horizontal flexible coupled) back pull out centrifugal pumps size ...x...x... of (standard fitted) (bronze fitted) (all iron) construction.

The contractor shall furnish (and install as shown on the plans) Aurora Model (361A horizontal close coupled) (362A vertical close coupled) (364A horizontal flexible coupled) back pull out centrifugal pumps size ...x...x... of (bronze fitted) (all bronze) (all iron) (stainless steel) construction. Each pump is to be furnished with a (standard) (water cooled) stuffing box with (packing) (...) (see options).

Each pump shall have a capacity of ...GPM at ...ft. total head, with a temperature of ...°F, ... specific gravity. Each pump is to be

furnished with a mechanical seal with all metal parts to be 303 stainless steel with "Buna-N" elastomers, Ni-Resist seat, and carbon washer. The unit must be equipped with (bronze) (stainless steel) keylocked shaft sleeve that extends the length of the seal box. The pump shaft extension shall be "O" ring sealed from the pumped liquid. Pump shall have a case wearing ring (impeller wearing rings). Impellers to be vacuum cast, dynamically balanced, and keylocked to the shaft.

Flexible Coupled-Frame Mounted (344A-364A)

Pump and motor are to be mounted on a common (fabricated steel drip rim) (steel) baseplate. The shaft is to be steel, installed in a cast iron power frame. Pumps shall have a shaft design for .002" deflection at the seal face with the pump running under maximum load condition. (Grease) (oil) (permanently lubricated) ball bearings, having a 3 year minimum

life (AFBMA B₁₀) under the maximum condition of load. Bearings to be protected by separate oil seals and slingers. The pump shall be flexible coupled to a standard horizontal NEMA ... HP ... phase ... Hertz ... volts ... RPM (open drip proof) (totally enclosed fan cooled) (explosion-proof) motor. Alignment shall be checked in accordance with the standards of the Hydraulic Institute after installation and there shall be no strain transmitted to the pumps.

Close Coupled (341A-361A) (342A-362A)

Each pump is to be close coupled to a standard HI-NEMA-JM (340A Series) JP (360A Series). HP ... phase ...Hertz ...volt ...RPM (drip-proof) (totally enclosed) (explosion-proof) motor. Model 341A and 361A in motor frame sizes up to 184JM shall be supported by a separate support foot on the close coupled pump bracket.



NOTE: Aurora Pump reserves the right to make revisions to its products and their specifications, and to this bulletin and related information, without notice.

— Your Authorized Local Distributor —



MARKETING & SALES:
800 AIRPORT ROAD • NORTH AURORA, ILLINOIS U.S.A. • 60542
PHONE: (630) 859-7000 U.S.A./CANADA FAX: (630) 859-7060
WORLDWIDE FAX: (630) 859-1226

AURORA MFG. PLANT:
800 AIRPORT ROAD • NORTH AURORA, ILLINOIS U.S.A. • 60542

SALES OFFICES IN ALL MAJOR CITIES AND COUNTRIES
Refer to "Pumps" in yellow pages of your phone directory for your local Distributor



AP-340A/360A / Rev. J 1.01 (10M 1.01)