

## Spectra-Clean™ Series Model - Wildcat G 5.5

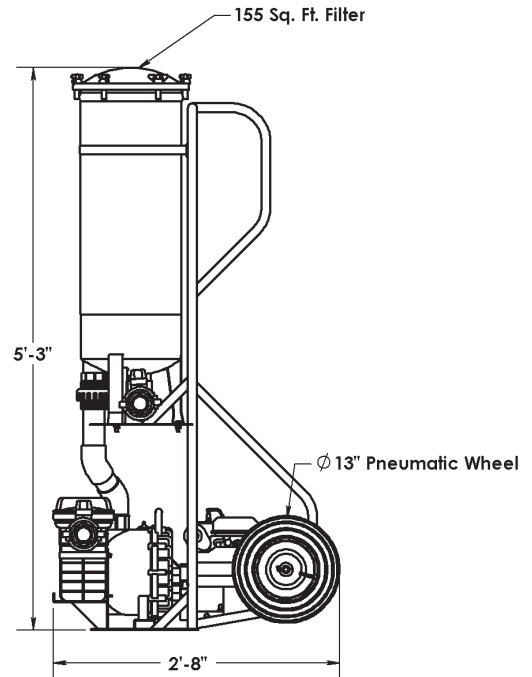

- 300 series stainless steel filter canister and cart
  - All metallic components are passivated for maximum corrosion resistance
- 155 square foot filter cartridge
- 13" pneumatic wheels
- 3.5 horsepower Briggs & Stratton gas engine and pump
- 2" shut off valves and quick-connect hose fittings
- Two year limited warranty



7100 Spectrum Lane  
Missoula, Montana 59808  
406.542.9781 800.791.8056  
Fax: 406.542.1158  
[www.spectrumproducts.com](http://www.spectrumproducts.com)

Spectra-Clean™ Series Model - Wildcat G 5.5  
Catalog No: 10640

Literature No: SA 10640.1106