

Spectra-Clean™ Series Model - Wildcat E 2

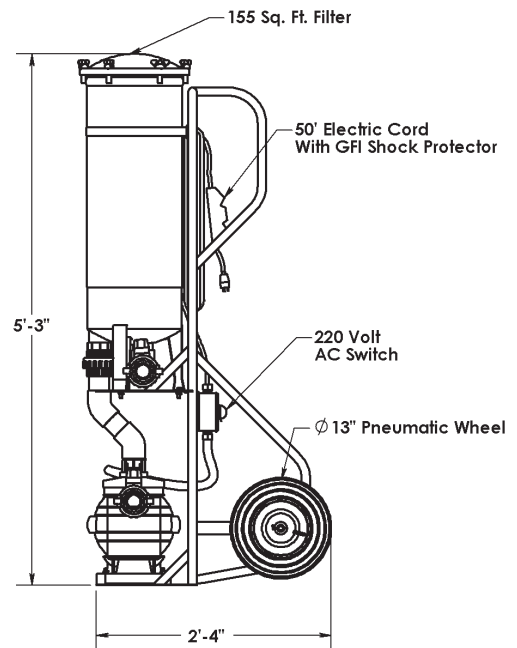

- 300 series stainless steel filter canister and cart
 - All metallic components are passivated for maximum corrosion resistance
- 155 square foot filter cartridge
- 13" pneumatic wheels
- 2 horsepower Sta-Rite®, Dyna-Max® pump
 - 220-volt
- 50' electrical cord
- GFIC shock protector
- 2" shut off valves and quick-connect hose fittings
- Two year limited warranty



7100 Spectrum Lane
Missoula, Montana 59808
406.542.9781 800.791.8056
Fax: 406.542.1158
www.spectrumproducts.com

Spectra-Clean™ Series Model - Wildcat E 2
Catalog No: 10620

Literature No: SA 10620.1106