



**PARAGON
AQUATICS**

Pentair Water

thinking toward the future... changing with the times



QUICKSET® DUAL-WEDGE™ STARTING PLATFORM ANCHOR

Innovative Anchor Design – no tools required.

FEATURES:

- ▶ Completing our Starting Platform package is the Quickset® Dual-Wedge™ Anchor. A combination of the *patented taper lock base* and *NEW dual acting wedge* design eliminates front-to-back and side-to-side movement.
- ▶ The Dual-Wedge Assembly has an integral adjusting knob which is easily turned by hand to install and remove the platform without the need for tools.
- ▶ The Dual-Wedge Assembly is a self-contained one-piece design readily removable and stored within the anchor when not in use. Anchor cover is included.
- ▶ One piece anchor body constructed of heavy duty T304 stainless steel will never need replacement parts.

Paragon Aquatics/Division of Pentair Water Pool & Spa, Inc.

1351 Route 55, LaGrangeville, NY 12540 USA

845.463.7200 • 888.KDI.SWIM • Fax: 845.463.7291

www.paragonaquatics.com

QUICKSET® DUAL-WEDGE™ STARTING PLATFORM ANCHOR SPECIFICATIONS



**PARAGON
AQUATICS**

Pentair Water

- 1** The main body of the anchor shall be constructed of 14 gauge T304 stainless steel.
- 2** Anchor base shall be Paragon patented taper-lock base to prevent movement of post at the bottom of anchor socket.
- 3** Dual-Wedge assembly shall consist of a PVC plastic wedge (dark gray) and T304 stainless steel hardware. PVC components are corrosion resistant.
- 4** Anchor shall not require tools to operate. Integrated plastic knob shall allow for tightening of wedge assembly. Wedge Assembly shall be removable for storage inside anchor socket when not in use.
- 5** Bonding/grounding screw shall be provided where grounding and bonding of anchor is required.
- 6** Anchor shall be provided with a cover, that when the anchor is not in use and the wedge assembly is inside the anchor, the cover slips in preventing debris from entering the anchor.

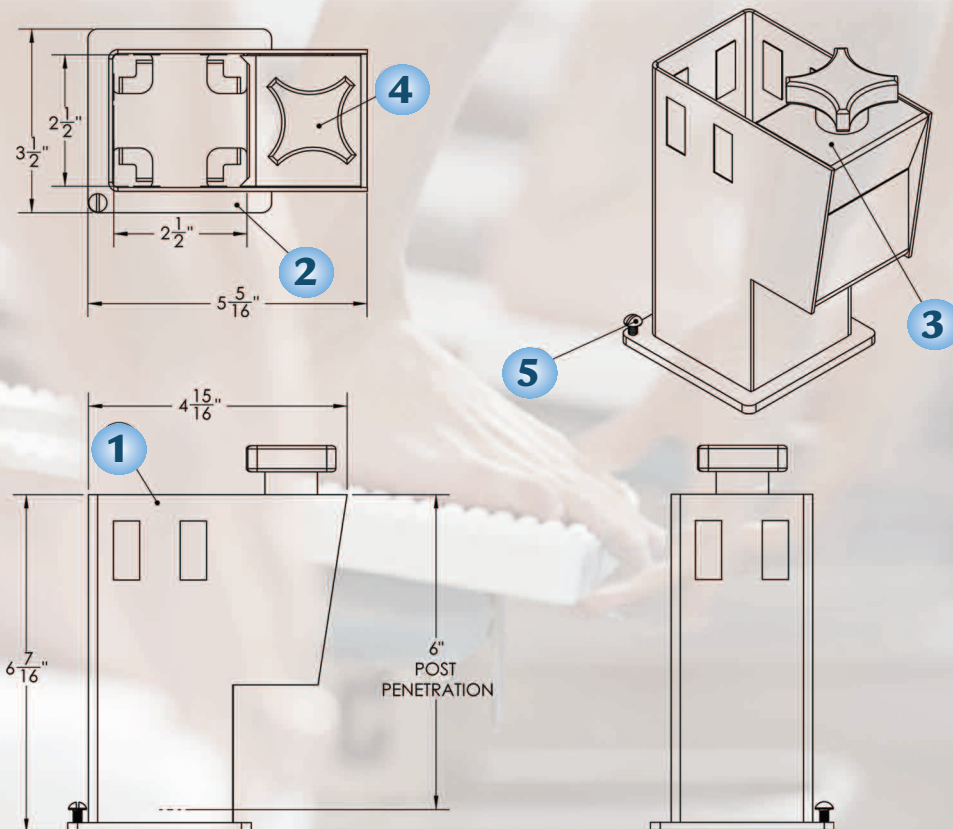
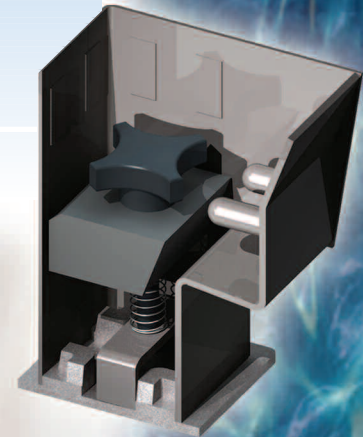

thinking toward the future... changing with the times