



Operator's Manual

Model #PS 8000



06.26.06

Arch Chemicals, Inc.
1955 Lake Park Drive
Smyrna, GA 30080
1-800-4-PULSAR



Product Stewardship
"Making the World a Better Place"

Arch is committed to maintaining and improving our leadership in Product Stewardship. One of the six initiatives outlined under the Chemical Manufacturers Association (CMA) Responsible Care® Program is to make health, safety, and environmental protection an integral part of a product's life cycle – from manufacture, marketing, and distribution to use, recycling, and disposal.

Successful implementation is therefore, a shared responsibility. Everyone involved with the product has responsibilities to address society's interest in a healthy environment and in products that can be used safely. We are each responsible for providing a safe workplace. All who use and handle products must follow safe and environmentally sound practices.

For more information about our Product Stewardship Program, contact your Arch Representative.

The Major Components - How They Work

General Principles of Operation

The three main components of the Pulsar® 4 Chlorinator are (from top to bottom) the briquette tank, the manifold spray section and the discharge tank. The water from the pool enters the Pulsar® 4 Chlorinator via the inlet port. The spray manifold then distributes the water onto the briquette grid creating a chlorinated solution. The chlorinated solution falls into the discharge tank and is discharged into the pool recirculation system by the evacuation system. The amount of chlorine discharged from the feeder is determined by the ORP controller or the Pulsar Timer/ Solenoid Assembly. When using an ORP controller with this unit the timer must be set on High (bottom knob) and an upper knob setting of "A". Inlet water pressure of 35 to 45 psi is required to provide sufficient flow into the Pulsar® 4. These pressures will result in an inlet flow of 2.6 gallons/minute. The Pulsar® 4 feed rate settings referred to in the Pulsar System Owners manual (above right) are calibrated for this flow rate. Flow out of the Pulsar® 4 discharge tank requires a vacuum to drain. A minimum outlet flow-rate of 2.7 gal/minute ensures that the flow out of the Pulsar® 4 exceeds the flow in. Once the Pulsar® 4 is installed, outlet flow can be measured by watching the level in the bottom tank. If the level is rising as the feeder is running, there is insufficient flow out.

Pounds of Available Chlorine Per Day							
Upper Timer Knob Setting	A	B	C	D	E	F	G
"Normal" Bottom Knob Setting	55	14	3.2	1.7	1.3	1.1	1.0
"Low" Bottom Knob Setting	90	24	6.5	3.6	2.5	2.0	1.8
"High" Bottom Knob Setting	120	30	7.4	4.1	3.0	2.4	2.2



SPECIFICATIONS – Model PS 8000

Operational Requirements:

Inlet pressure (Range)	35-45 psi
Ideal	37 psi
Outlet Vacuum	5-29" hg
Operating Temperature	40-130°F

Operational Characteristics:

Inlet flow	2.6 gpm
Outlet flow (Min.)	2.7 gpm

Note: To maintain NSF approval a flow indicator must be installed.

Dimensions:

Tubing	5/8" O.D. Polyethylene
Chlorinator dimensions	38" w x 33" d
Chlorinator height	39"
Chlorinator weight (full)	274 lbs
Chlorinator weight (empty)	74 lbs

Capacity

200 lbs Pulsar Plus Dry Chlorinator
Briquettes (equivalent 136 lbs. available chlorine per day)

Feed Rate:

Pulsar Plus Briquettes: 2.4 - 360 lbs of Available Chlorine per day

Recommend Pool Size¹

10,000–4000,000 gallon unstabilized
10,000–1,500,000 gallon stabilized

¹Subject to local health codes.

General principles of Pulsar® 4 Components

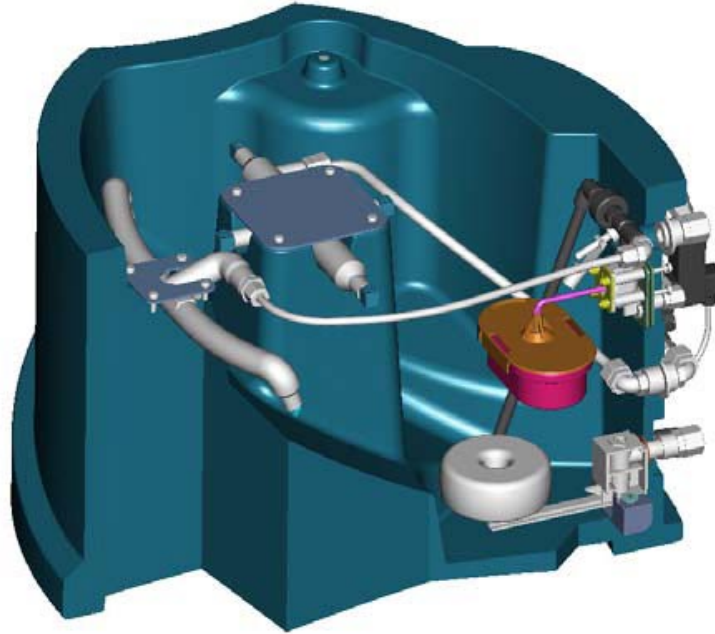

The Pulsar® 4 employs a “State of the Art” electronics package for efficient operation and enhanced safety features. The power to the chlorinator is reduced to 24v AC with the use of a wallmounted transformer. The Pulsar® 4 utilizes a 24 Volt Solenoid/Timer combination to control chlorine

output rates. Safety Switches are additionally used to interrupt spray to the nozzles when the lid is opened or when the hopper is removed. Pulsar® 4 also incorporates improved maintenance features. Water flow in the unit is designed to continually remove residue from the chlorinator base. Listed below is a description of each component of the Electronic Package:



Electronic Overflow Switch:

The Pulsar® 4 utilizes an Electronic Overflow Switch to prevent the unit from overflowing. Outlet flow can be slowed or stopped by many causes, which can ultimately lead to the unit overflowing. The most common cause would be scale

buildup in the venturi, discharge valve and/or outlet tubing. The electronic overflow switch will interrupt power to the solenoid if the level in the discharge tank reaches a set height. When power is interrupted, the solenoid will close and shut off the inlet flow to the spray manifold.



Lid Shut-off Switch:

The Pulsar® 4 is equipped with an Electronic Lid Shut-off Switch. This switch is designed for safety purposes to interrupt flow to the spray jets when the lid is opened.

The design of this feature incorporates a proximity

switch so there are no wires connecting the hopper to the chlorinator base. When the hopper is separated from the chlorinator base, power to the solenoid is turned off.



Solenoid / Timer Assembly

The Pulsar® 4 relies on a timer/solenoid assembly to control output rate. Both the timer and solenoid operate on a 24v AC power supply. The Pulsar® 4 can also be used in conjunction with an ORP controller. Under no circumstances should the unit be operated without the timer. Removing the timer/solenoid will not increase chlorine output and may actually cause a decrease in chlorine output. The Pulsar timer limits the inlet flow to the Pulsar® 4. This allows chlorine solution from the evacuation of system to keep up with inlet flow. When using the Pulsar® 4 with an ORP controller for an outdoor pool, it is recommended that the operator set the timer for a pool 30% larger in gallons than the one at their facility. If the pool is indoors, the timer should be set for a stabilized pool of the same size. The chart (see page 2) is for outdoor pools

that are either stabilized with cyanuric acid or not stabilized at all. Bather load constitutes the primary chlorine demand on an indoor pool. To verify the correct setting, set the timer and monitor the ORP reading. If the chlorinator does not respond quickly enough to chlorine demand, increase feed rate timer setting accordingly.



Test Operation of Electronic Switches:

Note: *Close inlet and outlet valves.*

Before start up, lift the briquette screen out of the hopper and set aside on a clean surface. Plug in transformer to appropriate outlet. The timer light (at upper left of timer) should be illuminated. Lift the hopper off the base. The light on the timer should go out. This indicates that the lid switch is working properly. Next, replace the hopper on the base and lift the lid. The light on the timer should go out. Finally, with the lid open use your hand to depress the lid shut-off switch. The light should go on. Keep the switch depressed and reach into the base, under the deflection plate and lift the electronic overflow switch. The light on the timer should go out. This concludes the test procedure. Should the test procedures fail, refer to the troubleshooting section for more information or contact your Dealer for additional information.

Safety Features

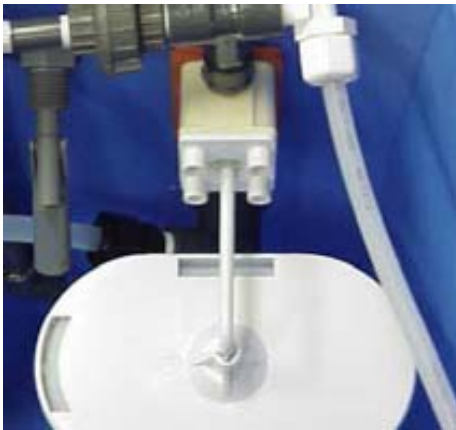

Washdown Emergency Shut-off Valve:

The Pulsar® 4 utilizes a mechanical emergency shut-off valve to interrupt flow to the Washdown manifold. This valve is mounted at a lower height than the electronic overflow switch. Insufficient outlet flow will cause this valve to close prior to the electronic overflow switch. This design allows the chlorinator to 4 continue to meet the chlorine demand of the pool in spite of decreased outlet flow. Since the washdown feature has been disabled, residue buildup in the discharge tank will require action to remedy the problem.

Overflow Port

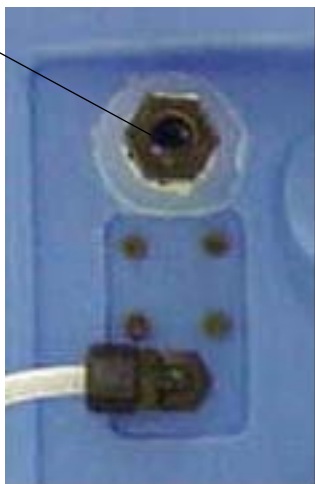

Overflow Port:

In the event that the solenoid fails to close, an overflow port has been incorporated into the Pulsar® 4 design. The solenoid should be checked when an abnormally low or high chlorine reading is indicated in the pool or when water is flowing out of the overflow port through the tubing down to the drain. Unplug the transformer from the wall or ORP unit and call the dealer. If water continues to flow into the chlorinator as evidenced by the rotating wheel in the flow indicator, the solenoid is stuck open. If flow stops when the transformer is unplugged, the problem is the electronic overflow switch. In either situation, the dealer should be contacted for additional information.

Well Agitator:

The well agitator is designed to keep insoluble material in suspension for removal by the suction created by the venturi. The nozzle at the bottom of the well agitator can become blocked by scale formation over time. The well agitator quick disconnect allows for easy removal and cleaning of the nozzle. Remove and place in dilute Pulsar® Acid Cleaner 50 solution (4 parts water to 1 part acid) to dissolve scale. Reinstall on chlorinator after scale is removed.



Drain Valve:

The drain valve is used to clean excess residue and scale buildup from the chlorinator discharge tank. It should be plumbed with 1" PVC pipe to a suitable drain or discharge area.

Deflection Plate:

The deflection plate protects the valves and floats from scale and residue deposits. Without this plate, scale and residue will increase float weight and decrease buoyancy. In addition, scale buildup can bind pivot points, which could result in valve failure.



Maintenance Features



Well Agitator:

The well agitator is designed to keep insoluble material in suspension for removal by the suction created by the venturi. The nozzle at the bottom of the well agitator can become blocked by scale formation over time. The well agitator quick disconnect allows for easy removal and cleaning of the nozzle. Remove and place in diluted Pulsar® Acid Cleaner 50 solution (4 parts water to 1 part acid) to dissolve scale. Reinstall on chlorinator after scale is removed.

PRE-START UP CHECKLIST

Following the procedure outlined below will ensure a smooth start-up of the Pulsar® 4 Chlorinator. For sea onal operation, perform this procedure each spring.

IMPORTANT!! *Do NOT put Pulsar® Plus Briquettes in the chlorinator during the start-up operation.*

INLET WATER FLOW:

The inlet water flow system is designed to provide a steady side stream of clean filtered pool water to the chlorinator.

1. Switch on the pool recirculation system, the Pulsar® booster pump, and open all valves to the chlorinator.
2. Check the flow indicator of the Pulsar® system to see that water is flowing into the chlorinator.
3. With lid open, depress switch to check to see that the four nozzles are spraying water onto the Briquette-Tank grid.
4. Check all lines leading to the Chlorinator for leaks. Hand tighten all fittings if any leaks are found.
5. Check to make sure Electronic shut-off switch does not contact ESV Float as it moves through it's arc.

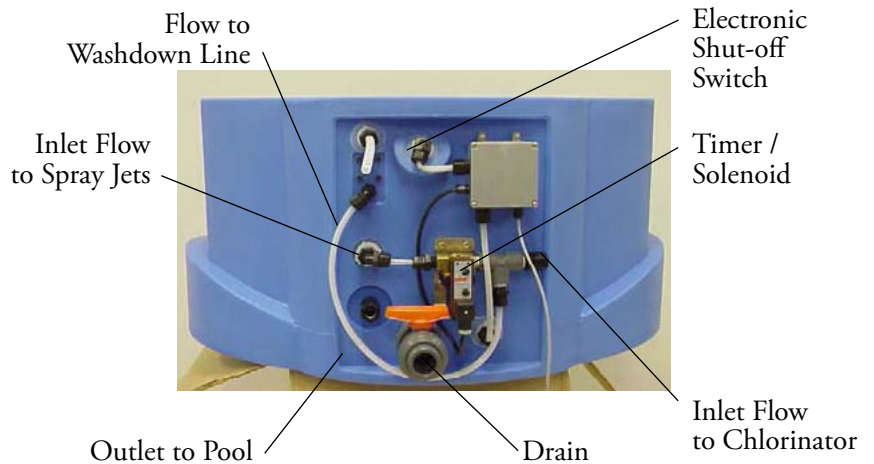

Following the procedure outlined below will ensure a smooth start-up of the Pulsar® 4 Chlorinator. For sea onal operation, perform this procedure each spring.

IMPORTANT!! *Do NOT put Pulsar® Plus Briquettes in the chlorinator during the start-up operation.*

OUTLET WATER FLOW:

The inlet water flow system is designed to provide a steady side stream of clean filtered pool water to the chlorinator.

1. Switch on the pool recirculation system, the Pulsar® booster pump, and open all valves to the chlorinator.
2. Check the flow indicator of the Pulsar® system to see that water is flowing into the chlorinator.
3. With lid open, depress switch to check to see that the four nozzles are spraying water onto the Briquette-Tank grid.
4. Check all lines leading to the Chlorinator for leaks. Hand tighten all fittings if any leaks are found.
5. Check to make sure Electronic shut-off switch does not contact ESV Float as it moves through it's arc.

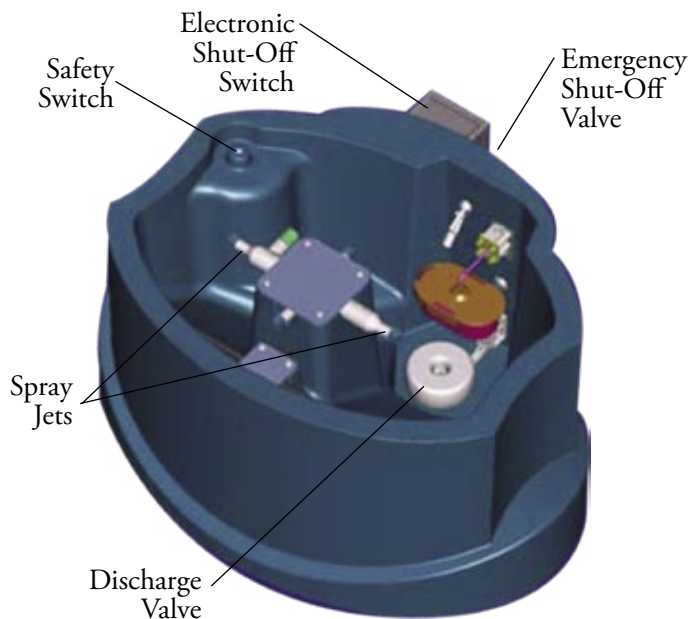

START UP PROCEDURES

After completing the PRE-START-UP CHECKLIST, and establishing that all components of the chlorinator are operating properly, the PULSAR® 4 Chlorinator is ready for start-up. Routine maintenance of the PULSAR® 4 Chlorinator is minimized when proper pool water balance is maintained. Maintain pool water chemistry as follows:

Total Alkalinity 60-80ppm
 Calcium Hardness 200-1800ppm
 PH 7.2-7.6

Adherence to these recommendations at all times will ensure the most effective and economical performance from the PULSAR® 4 Chlorinator.

Note: *The use of CO2 to lower pH will raise Total Alkalinity. High total alkalinity (over 80 ppm) will increase scale and residue buildup in chlorinator.*

1. Fill the Briquette Tank with Pulsar® Plus Briquettes. The Briquette Tank holds 200 pounds of briquettes.
2. Check the chart below to determine an approximate start-up timer setting for your pool. (ORP Controller: Use pool size recommendation in Solenoid/Timer section on page 3 to be sure the controller is calibrated and the set-points are correct). Set the Upper and Lower Timer Knobs at the recommended setting.

Note: *For best chlorinator performance, use the “normal” bottom timer setting if pool size can be found in that column. If pool size is too large for “normal” setting, look next in “low” bottom timer setting column.*

3. Open all valves to the pool and to the chlorinator.
4. Monitor the water flow to the chlorinator daily to ensure that a proper flow is being maintained.
5. During the first few days of operation, check chlorine level in the pool frequently to establish the best Timer setting (or ORP Controller setting) for your pool. Adjust the chlorine output either up or down according to the table or, adjust the ORP setpoint.

WARNING: *Use ONLY Pulsar® Plus Briquettes in the Chlorinator. The use of any other chemicals will void the warranty.*

DANGER: *Under no circumstances mix calcium hypochlorite with other forms of concentrated chlorine or other chemicals. Fire and/or explosion may result. Caution must be used when refilling the briquette tank.*

KEEP OUT OF REACH OF CHILDREN

Recommended Start-Up Settings

Pool Size in thousands of gallons (000)						
Upper Timer Setting	High Bottom Timer Setting		Low Bottom Timer Setting		Normal Bottom Timer Setting	
	Unstabilized	Stabilized*	Unstabilized	Stabilized*	Unstabilized	Stabilized*
A	1,200	3,600	600	1,800	300	900
B	300	900	213	640	140	410
C	70	210	57	170	33	100
D	37	110	30	90	—	55
E	28	78	21	62	—	—
F	23	68	—	50	—	—
G	21	64	—	—	—	—

*Do not exceed 25 ppm stabilizer

PULSAR® 4 CHLORINATOR INSPECTION & MAINTENANCE

Calcium Hypochlorite by the nature of its manufacture contains a small amount of calcium carbonate. Proper water balance will minimize the buildup of calcium carbonate residue in the Pulsar® 4 Chlorinator; however, periodic cleaning of chlorinator components is normal and recommended. The following is a list of the parts to be cleaned and the proper procedures to do so.

Table of Contents

Suggested Inspection Frequency	Section	Contents
As Needed	Section A	Use of Pulsar® Plus Acid Cleaner 50 to remove solids and scale from the Pulsar® 4 Chlorinator
As Needed	Section B	Troubleshooting Guide

SECTION A

Cleaning PULSAR® 3 Chlorinator with PULSAR® Plus Acid Cleaner 50

Inspection: The residue build-up and cleaning frequency required for the unit will depend on the amount of Briquettes used and the pool water chemistry. Described below is the easiest way to remove residue and minor scale buildup using the PULSAR® Plus Acid Cleaner 50.

WARNING: *Do not use Muriatic Acid to perform the following procedures. Chlorine gas may evolve causing serious injury or possible death.*

Maintenance Procedure Steps:

1. Close the inlet and outlet shutoff valves to the chlorinator.
2. Lift the Briquette Tank off of the Discharge Tank. Remove the Briquette Grid and put the contents into a clean dry bucket. Be sure to remove all pieces of briquettes. Rinse off residue buildup on spray manifolds, deflection plate, floats, etc. with a hose and flush out discharge tank using the Drain Valve before proceeding. Close the Drain Valve.
3. Place the briquette grid in the shallow tub supplied. Fill with 2 gallons of water. Slowly pour 1 quart PULSAR® Plus Acid Cleaner 50 into tub. Fill the discharge tank 1" below overflow port and add 1 quart PULSAR® Plus Acid Cleaner 50. Frequent agitation may be required to dissolve residue and scale. Allow acid to dissolve residue and scale, evident by the foaming action. After 30 minutes, check for presence of scale on grid. If necessary, add additional PULSAR® Plus Acid Cleaner 50 to dissolve any remaining scale or scrape with putty knife.
4. Dispose solution from tub with backwash from filter.
5. Place Briquette tank on top of discharge tank; place the Briquette grid back into bottom of hopper. Rinse the Briquette grid thoroughly with water and open the inlet-shutoff valve and press the shut-off button to allow the spray to rinse the grid from the bottom. The solution from the Discharge tank will clean the discharge valve and tubing when the system is restarted.
6. Pour Pulsar® Plus Briquettes from bucket back into Briquette Tank. Resume operation.
7. Open inlet and outlet shut off valves to the chlorinator.

NOTE: *To reduce maintenance and increase the period between Grid cleanings, allow Briquette Tank to completely empty once a week.*



SECTION B TROUBLESHOOTER'S GUIDE

SECTION B

Troubleshooter's Guide

Problem	Cause	Solution
Insufficient water flow to chlorinator	Check water flow through spray nozzles	Clean spray nozzles with compressed air. Do not use mechanical cleaning method.
	Inlet Shutoff Valve closed	Open Inlet Shutoff Valve
	Emergency Shut Off Valve in closed position Solenoid Valve not operating	If ESV Valve is stuck, lower gently to reset Check with Dealer
Insufficient chlorine in pool	Feed rate/output too low	Increase feed rate/output on timer or ORP
	Chlorinator empty	Refill Briquette Tank with Pulsar® Plus Briquettes
	No inlet water flow	See insufficient water flow section
	Outlet/Shutoff Valve closed	Open Outlet Shutoff Valve
	Clogged Discharge Tubing	Refer to Section A or Replace discharge tubing
	Briquettes stuck together Clogged Briquette Tank Grid Clogged Venturi System	Tap side of Briquette Tank to loosen Refer to Section A Remove venturi – soak in tub with 50/50 mixture of water and Pulsar Plus Acid Cleaner solution.
Excess chlorine in pool	Automatic Controller Problem	Refer to automatic controller manual
	Feed rate/output too high	Decrease feed rate/output on timer
Air leaks	Discharge Tubing not properly installed in fittings	Reinstall Discharge Tubing
	Discharge Valve seat failure	Replace Discharge Valve Arm
	Scale prevents Discharge Valve from properly seating	Remove Discharge Valve Assembly and soak in diluted Pulsar Acid Cleaner 50 to remove scale
	Pinched O-rings in Tubing Connectors	Inspect O-rings on discharge side of feeder
Chlorinator overflow	Discharge Tubing clogged	Refer to Section A or replace Discharge Tubing
	Insufficient outlet suction	Check with Dealer
	Emergency shutoff valve failure	Check with Dealer

ELECTRIC TROUBLESHOOTING SECTION

General Overview

The purpose of this guide is to familiarize installation and maintenance personnel with the electrical functions of the Pulsar 4 and to assist in the "troubleshooting" of any electrical failures that may occur. The Pulsar 4 incorporates six electrical components and their associated wiring. Each component is critical in the safe operation and dispensing of the chlorinated solution.

Transformer:

The electrical system operates from a 24 Volt AC source provided by a U.L.-listed class-II energylimiting step-down transformer. The transformer's primary coil (the side connected to the 120 Volt source) is designed to "open like a fuse" when the transformer's VA (Volt Amp.) rating is exceeded. When the primary coil opens the 24 Volt source is removed from the secondary electrical components, preventing overheating of components, wiring and possible electrical shock hazard.

Junction Box:

The transformer, Lid Shut-off Switch, Electronic Overflow Switch and Solenoid/Timer Assembly are wired to the junction box terminal strip (Fig. 1 & 2). A relay is mounted in the junction box to remove the 24 Volt supply from the Solenoid/Timer Assembly if the chlorinator lid is removed or if the chlorinator tank overfills.

Lid Shut-off Switch:

When the chlorinator lid is opened the Lid Shut-off Switch energizes the junction box relay which removes the 24 Volt source from the Solenoid/Timer assembly and causes the water solenoid valve to close (refer to manual for picture).

Electronic Overflow Switch:

When the water level reaches a pre-determined height in the chlorinator tank the Electronic Overflow Switch energizes the junction box relay removing the 24 Volt source from the Solenoid/Timer Assembly which causes the water solenoid valve to close (refer to manual for picture).

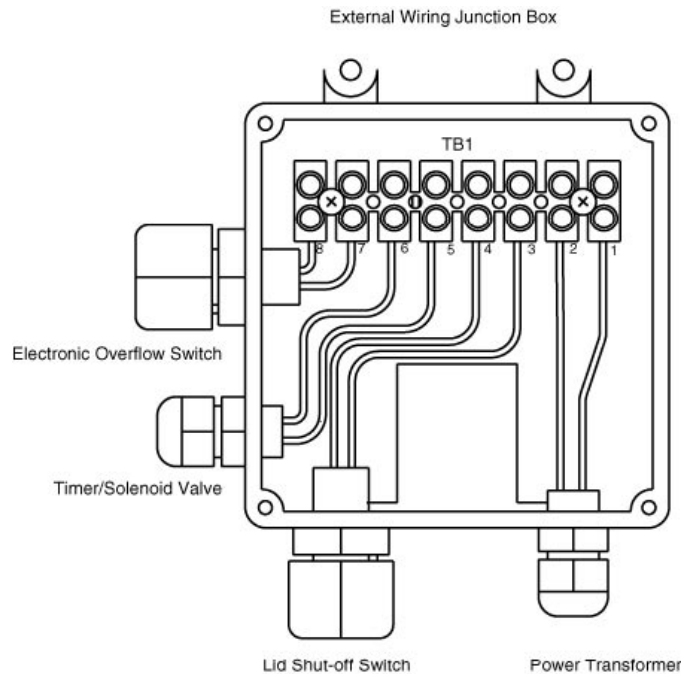

Figure 1 - Junction Box Terminator Strip

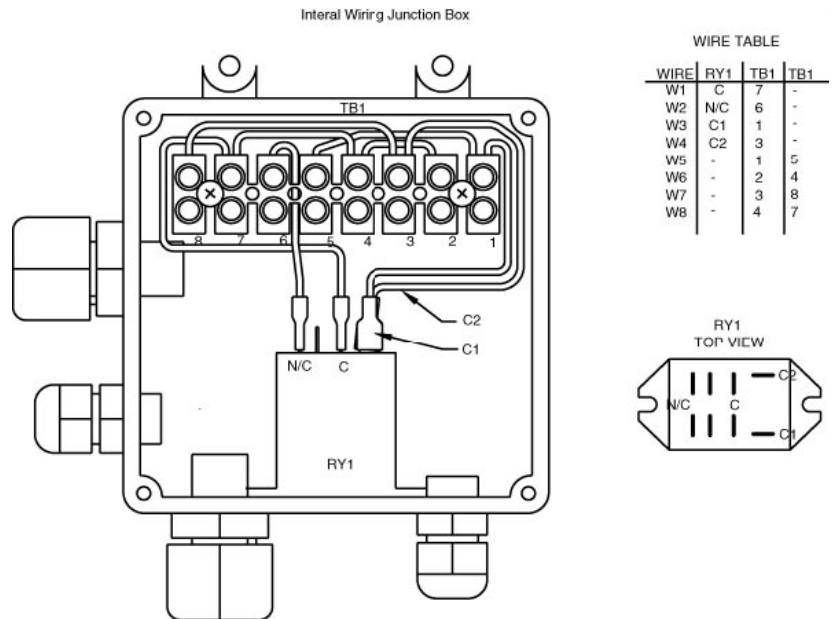

Figure 2 - External Wiring Junction Box Terminal Strip

ELECTRIC TROUBLESHOOTING SECTION

Solenoid/Timer Assembly:

The Solenoid/Timer Assembly consists of the timer module which is plugged into the solenoid actuated water valve.

Timer Module:

The timer module (Fig. 4) turns on and off the water solenoid valve at an adjustable on/off cycle to maintain a balance between the inlet water and the discharged chlorine solution. The timer has two controls -- one to adjust the ON time to: 11 seconds = Normal, 22 seconds = Low, and 30 seconds = Hi; and the second to adjust the DELAY time in seconds (i.e., A = 19 secs to G = 53 minutes).

WARNING: While turning the upper and lower timer knobs, **DO NOT FORCE** the knob beyond their stop points. Doing so will cause damage to the controls.

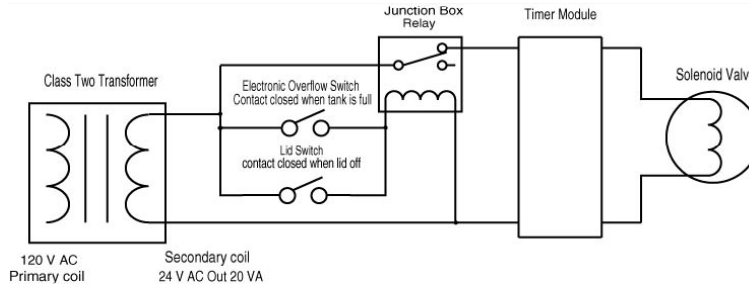

Timer Settings:

Top Knob (off time)	Bottom Knob (on time)
A – 19 seconds	High – 30 seconds
B – 3.2 minutes	Low – 22 seconds
C – 14.0 minutes	Normal – 11 seconds
D – 27.0 minutes	
E – 39.0 minutes	
F – 50.0 minutes	
G – 53.0 minutes	

Time Calculation Examples:

Example #1:

Top Knob (off time) set to “A” and Bottom Knob (on time) set to “HIGH”

Total cycle time = A (19 seconds “off time”) + HIGH (30 seconds “on time”) = 49 seconds

$$\% \text{ on time} = \frac{\text{on time}}{\text{Total cycle time}} \times 100 \quad \text{or} \quad \frac{30}{49} = 61.2\% \text{ on time}$$

Example #2:

Top Knob set to “B” and Bottom Knob set to “LOW”

Total cycle time = B (192 seconds “off time”) + LOW (22 seconds “on time”) = 214 seconds

$$\% \text{ on time} = \frac{\text{on time}}{\text{Total cycle time}} \times 100 \quad \text{or} \quad \frac{22}{49} = 10.28\% \text{ on time}$$

Water Solenoid Valve:

When the 24 Volt source is applied from the timer module to the solenoid coil of the water valve a magnetic core retracts into the solenoid coil allowing water to flow through the valve and into the chlorinator tank.

Troubleshooting Guide

Step-by-step Electrical System Test

1. Close water inlet and outlet valves
2. Verify that the Power transformer is plugged into a wall receptacle that has been tested to verify that power is present. Verify timer module power light is on (see Fig. 4). If power is on go to next step, if not meter test.
3. Lift the hopper off the base -- does the power light go out? If light goes out replace the hopper on it's base and go to next step, if not go to the meter test.
4. Lift hopper lid with your hand. Did the power light go out? If yes, then press the lid switch down and hold, did the light come on? If yes then while depressing the lid switch reach under the deflection plate and lift the electronic ove flow switch, did the light go out?
If yes, then the lid and electronic overflow switches are functioning properly and the 24 Volt power source is applied to the timer module. Go to the next step. If not go to the Meter Test.

READ THE FOLLOWING INSTRUCTION STEPS BEFORE CONTINUING THE TEST. THE TIMER MODULE MAY BE DAMAGED IF NOT PERFORMED CORRECTLY.

5. Turn the upper timer module control knob fully clockwise and counter-clockwise to verify that the knob comes to a stop at each end of the rotation. Be careful not to force the knob beyond the stop. If the knob rotates fully then the control knob is broken and the timer module must be replaced. Perform this test on the lower control knob.
Again, **DO NOT FORCE** the knob.
Replace the timer if defective and go to the next step.

6. Set the upper control knob to the "A" (19 seconds solenoid off time) position and the lower control knob to the "normal" (11 seconds solenoid on time) position. Verify that the timer module power light is on. Watch the valve light. It should come on for 11 seconds and off for an 19 seconds. During this test the solenoid valve will click at the start and end of the duty cycle and may hum while the valve light is on. This verifies that the solenoid coil is not defective. If the solenoid valve does not click on then vibrate during the on portion of the duty cycle the solenoid coil of the solenoid water valve must be replaced. If the light cycles on and off, go to the next step. If not the timer module is defective and must be replaced.

7. Turn both the inlet and outlet water valves on to verify that water is available and watch for water flow. When the timer module valve light is on and the solenoid coil is vibrating the water should begin to flow. When the timer module light is off the solenoid coil should stop vibrating and the water should stop flowing. If the valve comes on and off then the electrical system is performing correctly. If the water fails to start or stop flowing then the valve portion of the solenoid water valve is defective and must be replaced or repaired.

Restore the timer modules upper and lower control knobs to their previous times or refer to the owners manual for instruction.

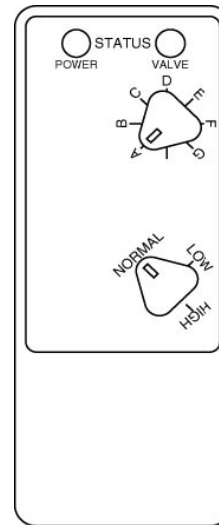

Figure 4

Meter Test

The following tests should be performed utilizing a volt meter (ref. Fig.5 – detailed schematic & Fig.6 -- meter placement). The following test is performed using a volt meter set on AC Voltage with a voltage scale set greater than 24 Volts. The lid of the hopper should be closed and on its base and the electronic overflow switch should not be in the up position. Connect the meter leads to the terminal board (TB1) as instructed in the following steps (see Fig. 6).

1. Connect the meter test leads to terminals 1 and 2 of the TB1. The meter should indicate 24 volts. If the reading is correct go to next step. If no voltage is present, check the wiring to the power transformer and verify that power is present at the outlet that the transformer is plugged into. If the wiring is correct and the outlet power is verified then the transformer is defective and must be replaced.

2. Connect the meter test leads to terminals 1 and 3 of TB1. No voltage should be present. While observing the meter, lift the lid of the hopper. The meter should read 24 volts and return to zero when the lid is replaced. Lift the hopper off its base. The meter should indicate 24 volts and return to zero when the base is replaced. Lift the hopper lid and press down the lid switch. Reach under the deflection plate and lift the electronic overflow switch. The meter should indicate 24 volts with switch in the up position and return to zero when released. During the next test, remove power to the junction box between each step by unplugging the transformer from the power outlet. Once the wire is removed from the terminal strip and is isolated, restore power to the junction box and perform the test. If 24 volts is always present during the above tests the hopper lid switch and/or the electronic overflow switch may be defective and must be disconnected from the terminal strip TB1 one at a time. Refer to Fig. 1 and disconnect the wire to terminal 3 of TB1. Observe the meter. The 24 volts may or may not return to zero. If the voltage returns to zero then the lid switch is defective and must be replaced. If the 24 volts remain with terminal 3 disconnected leave the wire to terminal 3 disconnected and perform the same test with the electronic overflow switch. Disconnect the wire to terminal 7. Again the 24 volts should return to zero. If not the electronic over flow switch is defective or is stuck in the up position. Remove power to the Junction box and reconnect the wires to terminal 3 and 7.

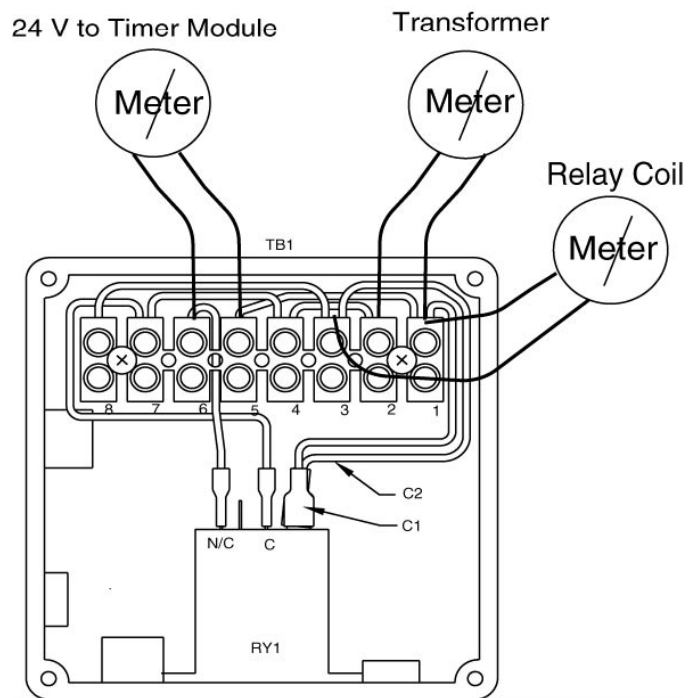
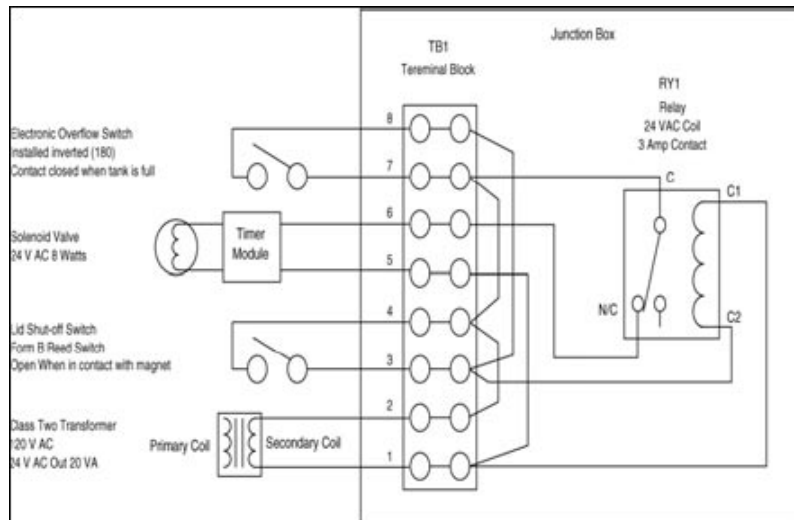

3. Connect the meter test leads to terminals 5 and 6. If 24 volts is present, but the power light on the timer module is off, then the timer module or its wiring is defective. If 24 volts are not present then the relay RY1 is defective and must be replaced.

WARRANTY POLICY

Pulsar® 4 Commercial Pool Chlorinator

Arch Chemicals, Inc. ("Arch") warrants equipment of its manufacture and bearing its identification to be free of defects in workmanship and material. Arch's liability under this warranty extends for a period of two (2) years (excluding electrical components which carry a 1 year warranty) from the date of installation as performed by an Authorized Commercial Dealer Representative and registered with Arch Water Chemicals via the Arch Commercial Chlorinator Warranty Registration Card. Systems for which there is no Warranty Registration Card on file carry no warranty of any kind, expressed or implied.

In addition, each system is covered by a sixty (60) day, 100% buy-back guarantee. If the original purchaser ("owner") is dissatisfied with the Pulsar® 4 Commercial Pool Chlorinator performance for any reason, they can return it to the Authorized Commercial Pool Dealer for a full refund. The equipment must have received normal use and care, and Arch must be notified in writing before the sixty (60) days have expired. There is no reimbursement for chemicals used during the sixty (60) days. Arch disclaims all liability for damage during transportation, for consequential damage of whatever nature, for damage due to handling, installation or improper operation, and for determined suitability for the use intended by purchaser ("owner"). Arch makes no warranties, either expressed or implied, other than those stated above. No Arch Representative or Authorized Commercial Dealer Representative has authority to change or modify this warranty in any respect.

Pulsar® 4 Parts

Arch warrants equipment parts of its manufacture and bearing its identification to be free of defects in workmanship and material. Arch's liability under this warranty extends for a period of ninety (90) days from the date of installation as performed by an Authorized Commercial Dealer Representative. This warranty is restricted to Pulsar® 4 Chlorinator Parts purchased on a replacement basis.

**Arch Water Chemicals, Inc.
1-800-4 PULSAR**

Pulsar® 4 Detailed View

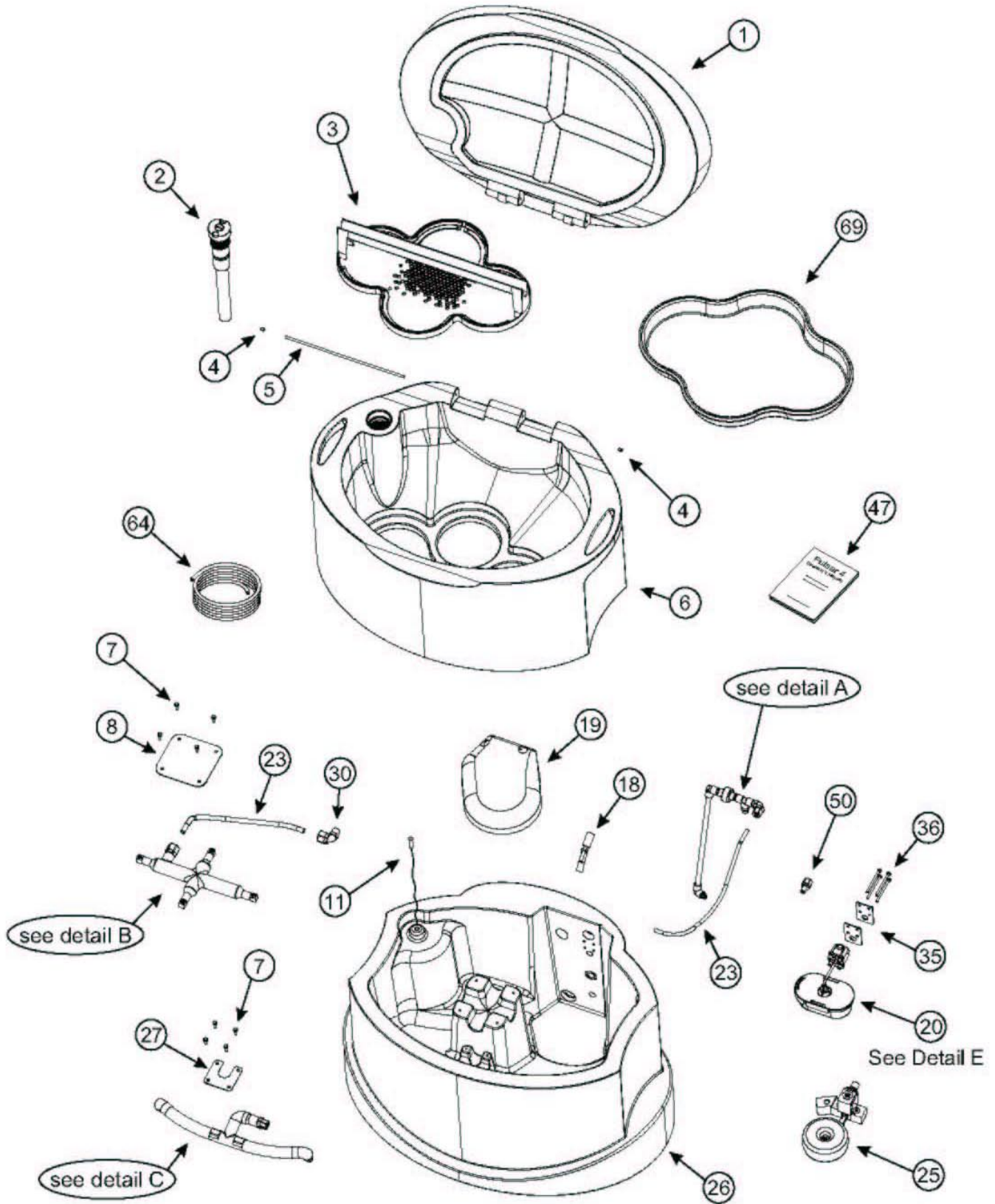

rev 01-15-03

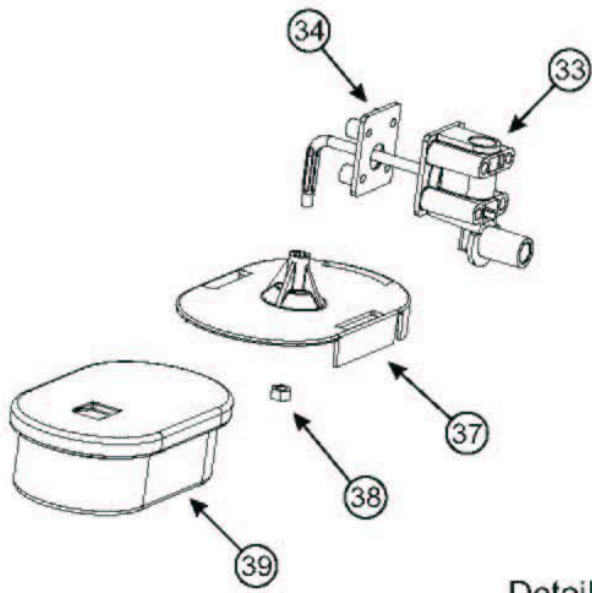

Detail E

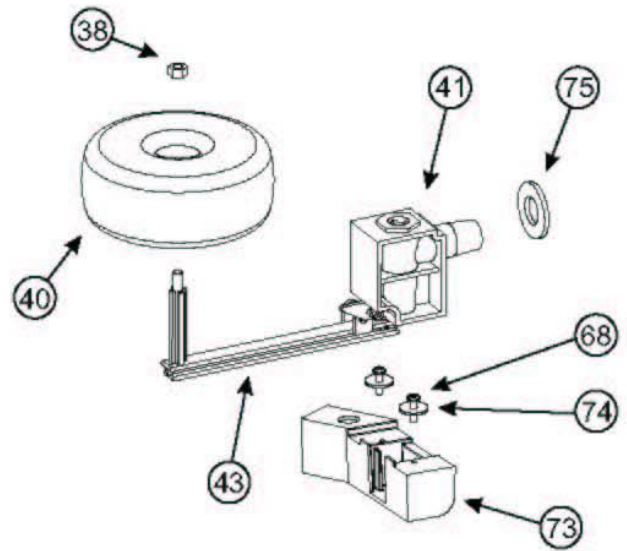

Detail of 25

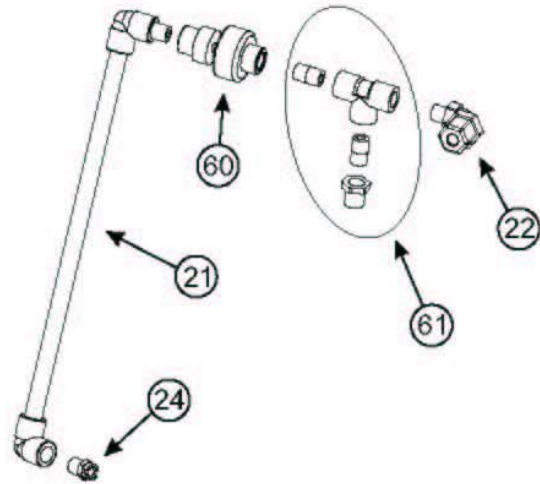

Detail A

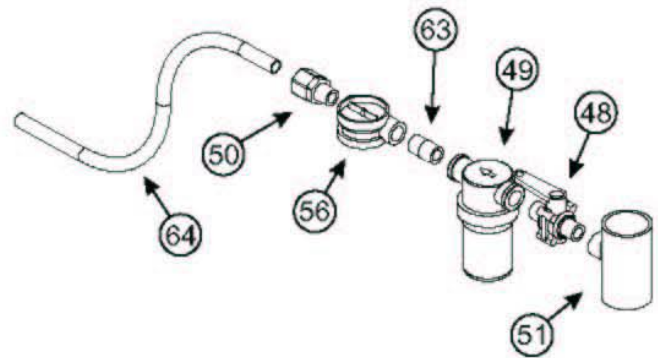

Detail D

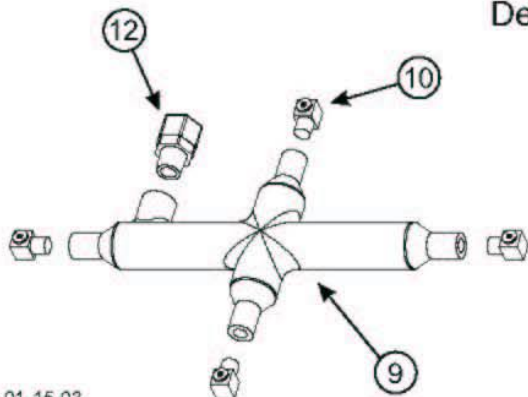

Detail B

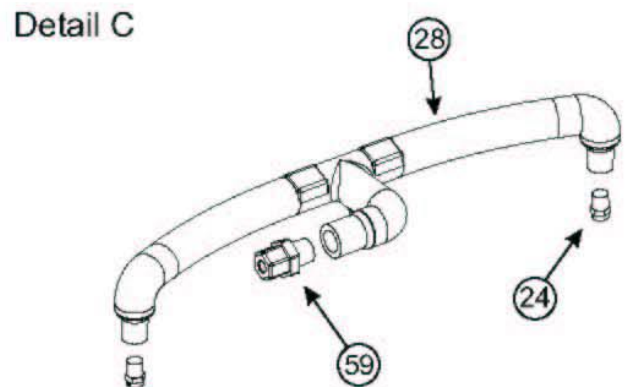

Detail C

rev 01-15-03

Pulsar® 4 Rear Control Panel Detailed View

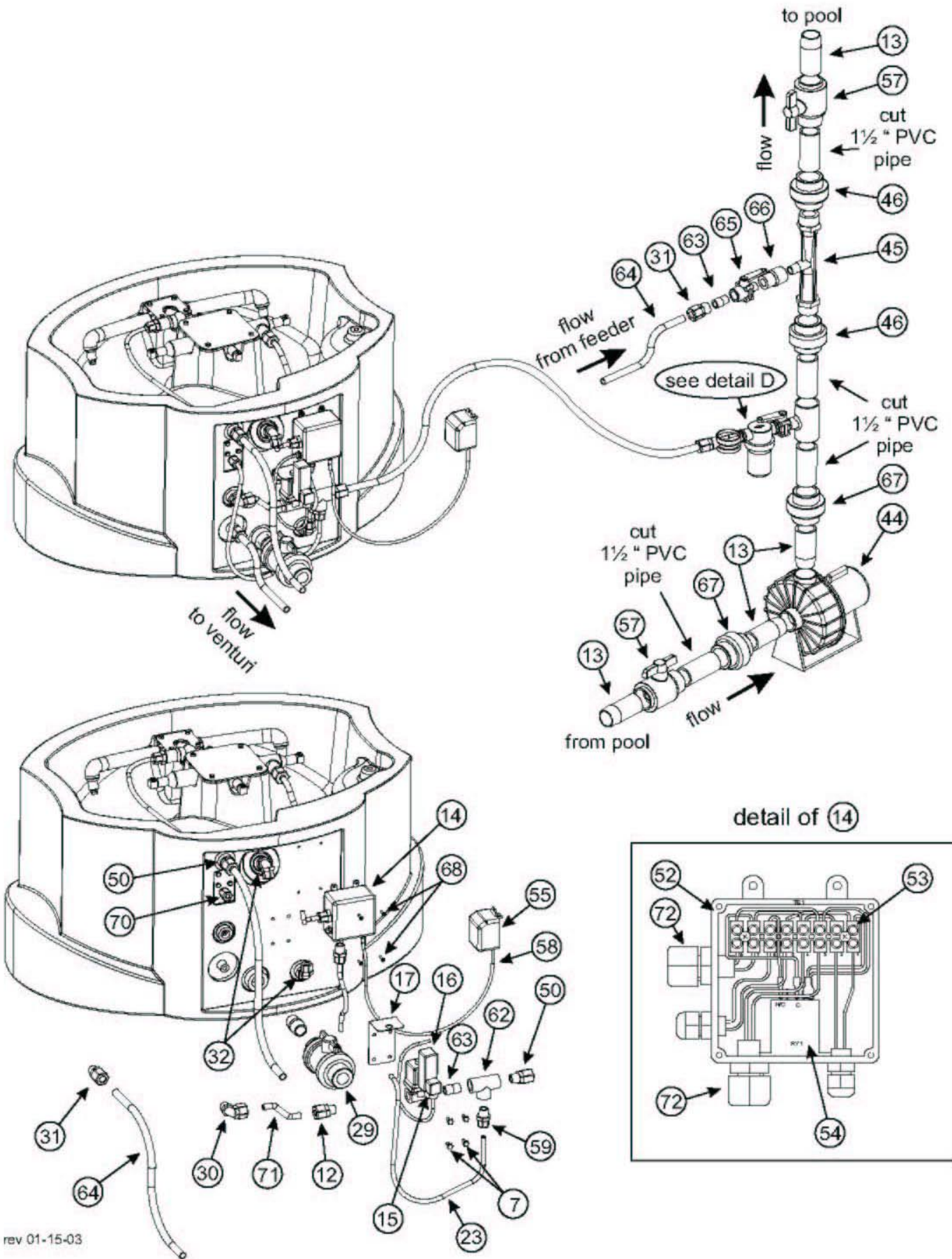

rev 01-15-03

Pulsar® 4

Diagram Number	Part Number	Qty	Description
0	71806	1	Pulsar 4 System
1	71879	1	Lid for Pulsar 4 Feeder
2	71880	1	Shut Off Assembly for Pulsar 4
3	71881	1	Briquette Screen Assembly for Pulsar 4
4	71882	2	Screw for Pulsar 4 lid
5	71883	1	Hinge Rod for Pulsar 4 lid
6	71884	1	Pulsar 4 Hopper
7	71885	12	Hex Nut Plastic Screw, 1/4-20, 5/8"
8	71886	1	Mounting Plate for Spray Tree
9	71887	1	Spray Tree
10	71888	4	Spray Nozzle for Spray Tree (Full Cone)
11	71889	1	Lid Switch
12	71890	2	Parker Fitting, W8MC8 (also for solenoid)
13	71548	2	1 1/2" X 12" PVC Nipple
14	71920	1	Junction Box, Complete Assembly Pulsar 4
15	71893	1	Timer (Pulsar 4) Includes Cord/Din Connector
16	71894	1	Solenoid (24 Volt) Pulsar Line
17	71895	1	Bracket for Timer/Solenoid
18	71896	1	Electronic Shut Off
19	71897	1	Deflection Plate
21	71919	1	Well Agitator
22	71900	1	Parker fitting W6ME4
23	71618	1	3/8" PE Tubing (2 ft)
24	71901	3	Spray nozzles for Washdown , Flat Fan
26	71903	1	Pulsar 4 Discharge Tank
27	71904	1	Washdown Mounting Plate
28	71905	1	Washdown Manifold
29	71906	1	1" drain valve (true union) With Nipple
30	71898	2	Parker Fitting W8ME8
31	71908	2	Parker Fitting W10FC8
32	71909	2	Parker fitting W6ME8
33	71535	1	Emergency Shut Off Valve with Arm Only
34	71536	1	Emergency Shut Off Mounting Plate
35	71910	2	Rubber Gasket for Emergency Shut Off Valve
36	71749	4	Plastic Screws (1/4-20) 3 1/4" for ESV (For Pulsar 4 Only)
37	71539	1	Emergency Shut Off Float Plate
38	71538	1	Emergency Shut Off Float Plate PVC Nut/Discharge Arm Nut
39	71540	1	Emergency Shut Off Overflow Float

Pulsar® 4

Diagram Number	Part Number	Qty	Description
40	71585	1	Discharge Valve Float
41	71615	1	Discharge Valve Body with Plug, Ball & Gasket
43	71584	1	Discharge Valve Arm with Suction Cup
44	71808	1	Pulsar 4 Pump (1 hp)
45	71811	1	Venturi for Pulsar Systems
46	71907	2	Unions(Quick disconnects) Venturi (Slip X Thread)
47	71915	1	Manual for Pulsar 4
48	71621	1	1/2" Ball Valve MM (Inlet)
49	71605	1	(5100A) Line Strainer Assembly
50	71918	3	Parker fitting W10MC8
51	71547	1	1 1/2" X 1/2" Schedule 80 PVC T SXF
52	71892	1	Junction Body w/Fittings
53	71921	1	Terminal Block
54	71922	1	Electronic Relay
55	71923	1	24V AC Transformer/Plug US
56	71928	1	Gem Sensors Flow Indicator (#155480) for Pulsar 4 only
57	71913	2	1 1/2" Slip PVC sch40 ball valves
58	71926	1	Power cord for Transformer (20 ft)
59	71590	2	(5023) 1/2" X 3/8" Male Connector (W6MC8)-Parker
60	71911	1	Union 1/4" Threaded
61	71899	1	Washdown assmby 2(1/4" clsd nipples), 1(1/4" threaded Tee), 1(3/8" MNPT X1/
62	71912	1	1/2" Threaded Tee
63	71916	3	1/2" PVC Closed Nipple
64	71891	1	20' Flexible Tubing 5/8"
65	71627	1	1/2" Ball Valve MF (Outlet)
66	71917	1	3/4" FNPT X 1/2" FNPT PVC Reducer
67	71914	2	Quick Disconnects (Pump) Slip X Slip
68	71925	4	8 - 32X5/8" PVC Screws
69	71927	1	Briquette Cleaning Pan for Pulsar 4
70	72006	1	Parker Fitting W6MC4
71	71626	1	20' 1/2" O.D. PE Tubing(P4 only need 3 inch piece)
72	71582	2	(4014) Parker Fitting P6MC4
73	72863	1	Discharge Valve Enhancement Adaptor
74	72865	2	Custom Washer for Discharge Valve Adapter
75	71576		Discharge Valve Gasket - P4

Arch Chemicals, Inc. Emergency Action Network (ACEAN)

The Arch Chemicals, Inc. Emergency Action Network ("ACEAN") is Arch's emergency action system. Call the ACEAN system at 1-800-654-6911 in North America, and at (Country Code for the United States) 423-780-2970 elsewhere in the world. The ACEAN system is available 24 hours a day, 7 days a week for assistance with spills, injuries and emergencies of any kind. It uses computers and other systems to make Arch's environmental, technical transportation, toxicological and other expertise about its products readily available to anyone needing assistance. The ACEAN system also includes emergency response teams capable of providing on-site support throughout North America.

(800) 654-6911

(From outside North America, call after the country code for the US, 423-780-2970)

Additionally, in the event of an emergency, CHEMTREC (Chemical Transportation Emergency Center) should be contacted. CHEMTREC is a national center established by the Chemical Manufacturers Association (CMA) in Washington, DC, to relay pertinent emergency information concerning specific chemicals on request.

CHEMTREC has a 24-hour toll-free telephone number (800) 424-9300, intended primarily for use by those who respond to chemical transportation emergencies. CHEMTREC may also be accessed through the CMA website at www.cmahq.com.

Material Safety Data Sheets (MSDS) sheets can be ordered by contacting (800)-511-MSDS.

If you would like a copy of this manual in another language
please call:

1-800-4-PULSAR